

**Customer Care Solutions
RH-20 Series Transceivers**

**System Module and User
Interface**

Table of Contents

	Page No
Glossary of Terms	3
Introduction	6
Electrical Modules	6
Interconnection Diagram	6
System Module: Baseband	7
Baseband Module, technical summary	7
Environmental Specifications	8
Temperature Conditions	8
Humidity and Water Resistance	8
Baseband Technical Specifications	9
Absolute Maximum Ratings	9
DC Characteristics	9
Power Distribution diagram	11
Baseband External and Internal Signals and Connections	12
FM Radio Interface	13
External Signals and Connections	17
Keyboard (board-to-board) Connector	17
LCD Connector (Board to Board)	18
DC Connector	19
Bottom Connector	19
SIM connector	21
Internal Signals and Connections	21
Baseband Functional Description	23
Modes of Operation	23
No Supply	23
Back-up	23
Acting Dead	23
Active	23
Sleep Mode	24
Charging	24
Battery	24
Power Up and Reset	25
Power Up with PWR key	26
Power Up when Charger is connected	26
Power Up when Battery is connected	26
RTC Alarm Power Up	26
A/D Channels	27
FM Radio	28
Camera	29
IR Module	29
SIM Interface	29
ACI	30
External Accessory Regulator	31
External Audio	31
External Microphone Connection	31
External Earphone Connections	32
Internal Audio	33

IHF Speaker & Stereo Audio Amplifier	33
Internal Microphone	33
Internal Speaker	33
IHF Speaker & Stereo Audio Amplifier	34
Memory Block	35
Security	35
Clock distribution	35
Audio Control	36
Accessory identification and Power Supply	36
Backup Battery	37
RF Module Introduction	38
RF Frequency Plan	39
DC characteristics	40
Regulators	40
Typical current consumption	41
Power Distribution	42
RF characteristics	43
Channel Numbers and Frequencies	43
Main RF characteristics	43
Transmitter characteristics	44
Receiver characteristics	44
RF Block Diagram	44
RF Block Diagram RH-20	45
Frequency Synthesizers	46
Receiver	46
Transmitter	46
Other	46
Power Amplifier	47
RF ASIC Helgo	48
AFC function	48
Antenna	48
User interface modules	49
UI board 1dm	49
Keyboard	49
LCD	51
LCD & keypad illumination	52
Internal earpiece	52
IHF	52
Internal microphone	53
IR module	53
Vibra	53
Pop-Port system connector	54

Glossary of Terms

ACI	Accessory Control Interface
ADC	Analog-Digital Converter
AFC	Automatic Frequency Control
AGC	Automatic Gain Control
API	Application Programming Interface
ARM	Processor architecture
ASIC	Application Specific Integrated Circuit
BB	Baseband
CBus	Control Bus connecting UPP_WD2 with AEM and UEM
CCS	Customer Care Solutions
CMT	Cellular Mobile Telephone (MCU and DSP)
COG	Chip On Glass
CPU	Central Processing Unit
CTSI	Clocking Timing Sleep Interrupt
CSP	Chip Scale Package
CSTN	Colour Super Twisted Nematic
DAC	Digital-Analog Converter
DAI	Digital Audio Interface
DB	Dual band
DCT4	Digital Core Technology, 4th generation
DCN	Offset Cancellation control signal
DLL	Dynamic Link Library
DRC	Dynamic Range Controller
DSP	Digital Signal Processor

EFR	Enhanced Full Rate
EGPRS	Enhanced General Packet Radio Service
EMC	Electromagnetic compatibility
EMI	Electromagnetic Interference
ESD	Electro Static Discharge
EXT RF	External RF
FBUS	Asynchronous Full Duplex Serial Bus
GPRS	General Packet Radio Service
GSM	Global System for Mobile communications
HS	Half Rate Speech
HSCSD	High Speed Circuit Switched Data
IC	Integrated Circuit
IHF	Integrated Hands Free
IMEI	International Mobile Equipment Identity
I/O	Input/Output
IRDA	Infra Red Association
LCD	Liquid Crystal Display
LDO	Low Drop-Out
LED	Light Emitting Diode
LNA	Low Noise Amplifier
MBUS	1-wire half duplex serial bus
MCU	Micro Controller Unit
MDI	MCU-DSP Interface
MFI	Modulator and Filter Interface

PA	Transmit Power Amplifier
PC	Personal Computer
PCM	Pulse Code Modulation
PCM SIO	Synchronous serial bus for PCM audio transferring
PIFA	Planar Inverted F-antenna
PWB	Printed Wiring Board
PWM	Pulse Width Modulation
RF	Radio Frequency
RTC	Real Time Clock
SIM	Subscriber Identity Module
SW	Software
UEM	Universal Energy Management
UI	User Interface
UPP	Universal Phone Processor
VCXO	Voltage Controlled Crystal Oscillator
VCTCXO	Voltage Controlled Temperature Compensated Crystal Oscillator.

Introduction

Electrical Modules

The system module 1A0 consists of Radio Frequency (RF) and baseband (BB). User Interface (UI) contains display, keyboard, IR link, vibra, system connector and audio parts.

FM radio is located on the main PWB 1A0.

The electrical part of the keyboard is located in separate UI PWB named 1dm. 1dm is connected to radio module PWB through a spring connector.

The Baseband blocks provide the MCU, DSP, external memory interface and digital control functions in the UPP ASIC. Power supply circuitry, charging, audio processing and RF control hard ware are in the UEM ASIC.

The purpose of the RF block is to receive and demodulate the radio frequency signal from the base station and to transmit a modulated RF signal to the base station.

The UI module is described in this section of the manual.

Interconnection Diagram

Figure 1: Interconnection diagram

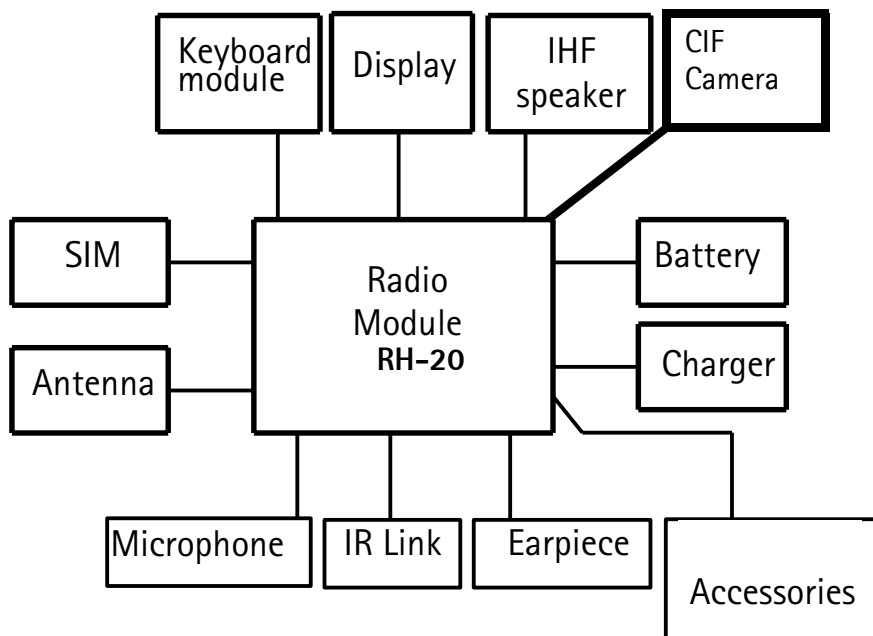

System Module: Baseband

The System module (or Engine) consists of Baseband and RF sub-modules, each described below.

Baseband Module, technical summary

Main functionality of the baseband is implemented into two ASICs: UPP (Universal Phone Processor) and UEM (Universal Energy Management).

Figure 2: Baseband block diagram

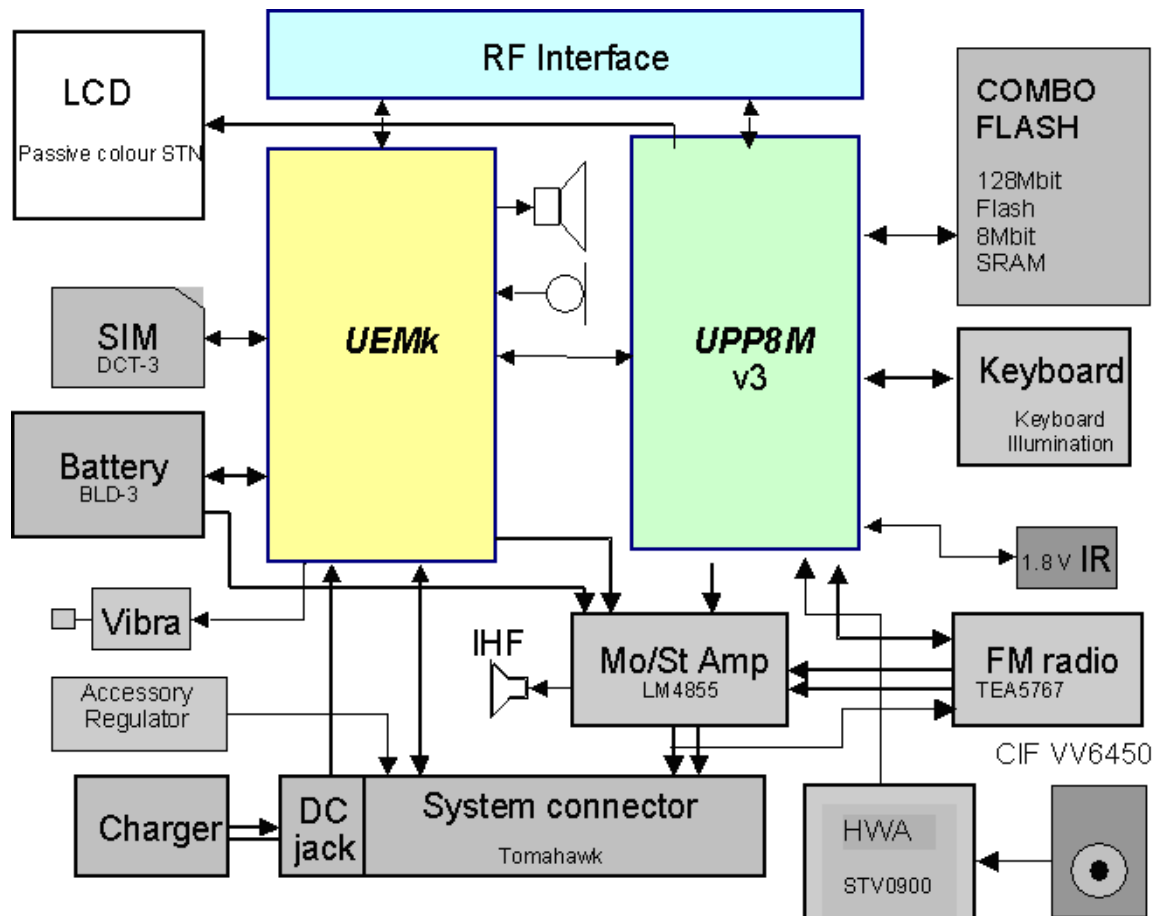

Baseband is running from power rails 2.8V analog voltage and 1.8V I/O voltage. UPP core voltages can be lowered down to 1.0V, 1.3V and 1.5V. UEM includes 6 linear LDO (Low Drop-Out) regulator for baseband and 7 regulators for RF. It also includes 4 current sources for biasing purposes and internal usage. UEM also includes SIM interface which supports both 1.8V and 3V SIM cards. **Note:** 5V SIM cards are no longer supported by DCT-4 generation baseband.

A real time clock function is integrated into the UEM. RTC utilizes the same 32kHz clock supply as the sleep clock. A backup power supply is provided for the RTC-battery, which keeps the real time clock running when the main battery is removed. The backup power supply is a rechargeable surface mounted Li-Ion battery. The backup time with the battery is 30 minutes minimum.

The UEM ASIC handles the analog interface between the baseband and the RF section. UEM provides A/D and D/A conversion of the in-phase and quadrature receive and transmit signal paths and also A/D and D/A conversions of received and transmitted audio signals to and from the user interface. The UEM supplies the analog TXC and AFC signals to RF section according to the UPP DSP digital control. Data transmission between the UEM and the UPP is implemented using two serial busses, DBUS for DSP and CBUS for MCU. There are also separate signals for PDM coded audio. Digital speech processing is handled by the DSP inside UPP ASIC. UEM is a dual voltage circuit, the digital parts are running from the baseband supply 1.8V and the analog parts are running from the analog supply 2.78V. Also VBAT is directly used (Vibra, LED-driver, Audio amplifier).

The baseband supports both internal and external microphone inputs and speaker outputs. Input and output signal source selection and gain control is performed by the UEM according to control messages from the UPP. Keypad tones, DTMF, and other audio tones are generated and encoded by the UPP and transmitted to the UEM for decoding. An external vibra alert control signals are generated by the UEM with separate PWM outputs.

RH-20 has a serial control interface: FBUS. FBUS can be accessed through a test pad and the System Connector as described later. EMC shielding is implemented using a metalized plastic frame. On the other side, the engine is shielded with PWB grounding.

Environmental Specifications

Temperature Conditions

Full functionality through ambient temperature range -10 °C to +55 °C.

Reduced functionality between -25 °C to -10 °C and +55 °C to +75 °C.

Humidity and Water Resistance

Full functionality in humidity range is 5% - 95%.

Condensed or dripping water may cause intermittent malfunctions. Protection against dripping water is implemented.

Baseband Technical Specifications

Absolute Maximum Ratings

Signal	Note
Battery Voltage (Idle)	-0.3V - 5.5V
Battery Voltage (Call)	Max 4.7V
Charger Input Voltage	-0.3V - 16V

DC Characteristics

Regulators and Supply Voltage Ranges

Battery Voltage Range

Signal	Min.	Nom	Max	Note
VBAT	3.1V	3.6V	4.2V (charging high limit voltage)	3.1V SW cut off

BB Regulators

Signal	Min.	Nom	Max	Note
VANA	2.70V	2.78V	2.86V	$I_{max} = 80mA$
VFLASH1	2.70V	2.78V	2.86V	$I_{max} = 70mA$ $I_{sleep} = 1.5mA$
VFLASH2	2.70V	2.78V	2.86V	$I_{max} = 40mA$
VSIM	1.745V 2.91V	1.8V 3.0V	1.855V 3.09V	$I_{max} = 25mA$ $I_{sleep} = 0.5mA$
VIO	1.72V	1.8V	1.88V	$I_{max} = 150mA$ $I_{sleep} = 0.5mA$
VCORE	1.0V 1.235V 1.425V 1.710V	1.053V 1.3V 1.5V 1.8V	1.106V 1.365V 1.575V 1.890V	$I_{max} = 200mA$ $I_{sleep} = 0.2mA$ Default value 1.5V

Accessory Regulator

Signal	Min	Nom	Max	Note
Vout	2.72V	2.80	2.88V	$I_{max} = 70mA$

RF Regulators

Signal	Min	Nom	Max	Note
VR1A	4.6V	4.75V	4.9V	$I_{max} = 10\text{mA}$
VR2	2.70V 3.20V	2.78V 3.3V	2.86V 3.40V	$I_{max} = 100\text{mA}$
VR3	2.70V	2.78V	2.86V	$I_{max} = 20\text{mA}$
VR4	2.70V	2.78V	2.86V	$I_{max} = 50\text{mA}$ $I_{sleep} = 0.1\text{mA}$
VR5	2.70V	2.78V	2.86V	$I_{max} = 50\text{mA}$ $I_{sleep} = 0.1\text{mA}$
VR6	2.70V	2.78V	2.86V	$I_{max} = 50\text{mA}$ $I_{sleep} = 0.1\text{mA}$
VR7	2.70V	2.78V	2.86V	$I_{max} = 45\text{mA}$

Current Sources

Signal	Min	Nom	Max	Note
IPA1 and IPA2		0mA - 5mA		Programmable, +/-6% $V_{IPA1}, V_{IPA2} = 0\text{V} - 2.7\text{V}$
IPA3 and IPA4	50 μA	100 μA	105 μA	$V_{IPA1} = 0\text{V} - 2.7\text{V}$, UEM Internal

Power Distribution diagram

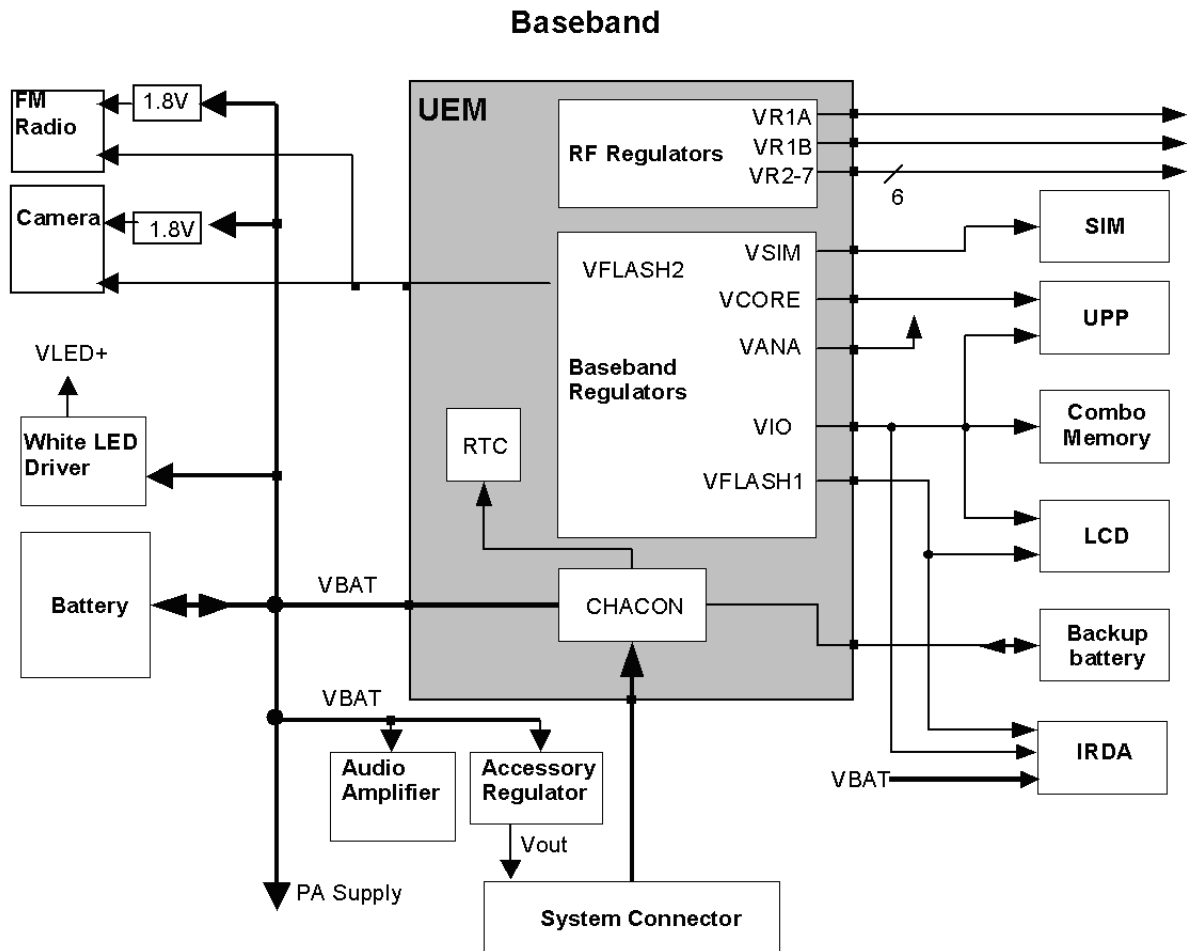

Baseband External and Internal Signals and Connections

This section describes the external and internal electrical connection and interface levels on the baseband. The electrical interface specifications are collected into tables that covers a connector or a defined interface.

Figure 3: RF/BB connections block diagram

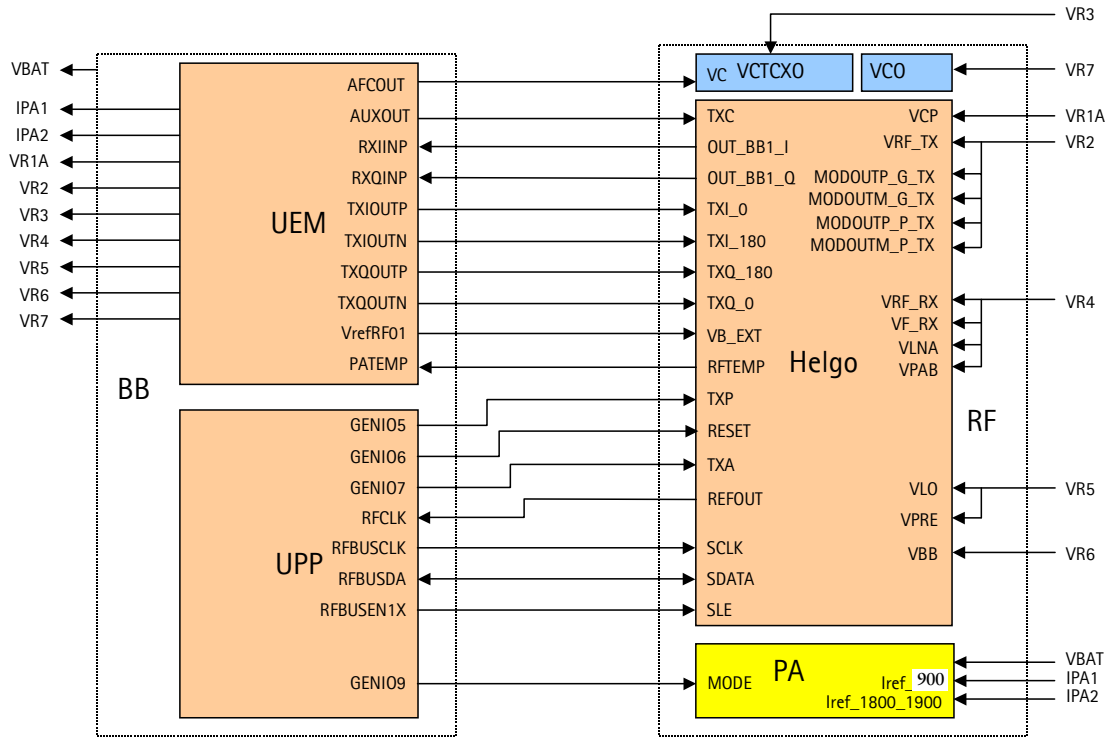

FM Radio Interface

BB Signal	FM Radio Signal	Min	Nom	Max	Condition	Note
VFLASH2	Vcca	2.7V	2.78V	2.86V		$I_{max} = 10.5 \text{ mA}$
	Vcc(vco)	2.7V	2.78V	2.86V		$I_{max} = 940 \mu\text{A}$
	Vccd	2.7V	2.78V	2.86V		$I_{max} = 3.9 \text{ mA}$
GenIO(3)	FMClk	1.4V 0	1.8V	1.88V 0.4V	High Low	Reference clock for FM radio module
			32kHz		Frequency	Also 6.5 MHz can be used
		30ppm			Stability	
GenIO(8)	FMWrEn	1.4V 0V	1.8V	1.88V 0.4V	High Low	Write/Read enable
GenIO(12)	FMCtrlDa	1.4V 0	1.8V	1.88V 0.6V	High Low	Bi-directional data
GenIO(11)	FMCtrlClk	1.4V 0	1.8V	1.88V 0.6V	High Low	
				1 MHz	Frequency	
FM Antenna	RFI1, RFI2	76 MHz		108 MHz		FM Input frequency
FM Radio L FM Radio R	VAFL VAFR		100mV	550mV		Audio level
		24 dB	30 dB		Channel separation	
		54dB	60 dB		(S+N)/N	
				2%	Harmonic distortion	

AC and DC Characteristics of RF-Baseband Voltage Supplies

Signal name	From	To	Parameter	Min	Typ	Max	Unit	Function
VBAT	Battery	PA, UEM	Voltage	2.95	3.6	4.2	V	Battery supply. Cut-off level of DCT4 regulators is 3.04V. Losses in PWB tracks and ferrites are taken account to minimum battery voltage level.

			Current			2000	mA	
			Current drawn by PA when "off"		0.8	2	μA	
VR1A	UEM	Helgo	Voltage	4.6	4.75	4.9	V	Supply for charge pump for SHF VCO tuning.
			Current		2	10	mA	
VR2	UEM	Helgo	Voltage	2.70	2.78	2.86	V	Supply for I/Q-modulators, buffers, ALS
			Current		65	100	mA	
VR3	UEM	VCTCXO, Helgo	Voltage	2.70	2.78	2.86	V	Supply for VCTCXO, PLL digital parts
			Current		1	20	mA	
VR4	UEM	Helgo	Voltage	2.70	2.78	2.86	V	Supply for Helgo RX; PA bias blocks.
			Current			50	mA	
VR5	UEM	Helgo	Voltage	2.70	2.78	2.86	V	Supply for Helgo PLL; dividers, LO- buffers, prescaler,
			Current			50	mA	
VR6	UEM	Helgo	Voltage	2.70	2.78	2.86	V	Supply for Helgo BB and LNAs
			Current			50	mA	
VR7	UEM	SHF VCO	Voltage	2.70	2.78	2.86	V	Supply for SHF VCO
			Current			30	mA	
VrefRF01	UEM	Helgo	Voltage	1.334	1.35	1.366	V	Voltage Reference for Helgo DCN2 op.amps.
			Current			100	μA	

AC and DC Characteristics of RF-Baseband Digital Signals

Signal name	From	To	Parameter	Input Characteristics				Function
				Min	Typ	Max	Unit	
TXP (RFGenOut3)	UPP	Helgo	"1"	1.38		1.88	V	Power amplifier enable
			"0"	0		0.4	V	
			Load Resistance	10		220	kΩ	

			Load Capacitance			20	pF	
			Timing Accuracy			1/4	symbol	
TXA	UPP	Helgo	"1"	1.38		1.88	V	Power control loop enable
			"0"	0		0.4	V	
			Load Resistance	10		220	kΩ	
			Load Capacitance			20	pF	
			Timing Accuracy			1/4	symbol	
RFBUSena1X	UPP	Helgo	"1"	1.38		1.88	V	RFBUS enable
			"0"	0		0.4	V	
			Current			50	μA	
			Load resistance	10		220	kΩ	
			Load capacitance			20	pF	
RFBUSData	UPP	Helgo	"1"	1.38		1.88	V	RFBUS data; read/write
			"0"	0		0.4	V	
			Load resistance	10		220	kΩ	
			Load capacitance			20	pF	
			Data frequency			10	MHz	
RFBUSClk	UPP	Helgo	"1"	1.38		1.88	V	RFBUS clock
			"0"	0		0.4	V	
			Load resistance	10		220	kΩ	
			Load capacitance			20	pF	
			Data frequency			10	MHz	
Mode Select (GENIO9)	UPP	Helgo	"1"	1.38		1.85	V	Mode Selection
			"0"	0		0.4	V	
RESET (GENIO6)	UPP	Helgo	"1"	1.38		1.85	V	Reset to Helgo
			"0"	0		0.4	V	
			Load capacitance			20	pF	
			Load resistance	10		220	kΩ	
			Timing accuracy			1/4	symbol	

AC and DC Characteristics of RF-Baseband Analogue Signals

Signal name	From	To	Parameter	Min	Typ	Max	Unit	Function	
VCTCXO	VCTCXO	UPP	Frequency	13		26	MHz	High stability clock signal for the logic circuits, AC coupled. Distorted sine-wave e.g. sawtooth.	
			Signal amplitude	0.2	0.8	2.0	Vpp		
			Input Impedance	10			kΩ		
			Input Capacitance			10	pF		
			Duty Cycle	40		60	%		
VCTCXOGnd	VCTCXO	UPP	DC Level		0		V	Ground for reference clock	
RXI/RXQ	Helgo	UEM	Voltage swing (static)	1.35	1.4	1.45	Vpp	Received demodulated IQ signals	
			DC level	1.3	1.35	1.4	V		
TXIP / TXIN	UEM	Helgo	Differential voltage swing (static)	2.15	2.2	2.25	Vpp	Programmable voltage swing. Programmable common mode voltage. Between TXIP-TXIN	
			DC level	1.17	1.20	1.23	V		
			Source Impedance			200	W		
TXQP / TXQN	UEM	Helgo	Same spec as for TXIP / TXIN						
AFC	UEM	VCTCXO	Voltage	Min Max	0.0 2.4		0.1 2.6	V	Automatic frequency control signal for VCTCXO
			Resolution		11			bits	
			Load resistance and capacitance		1		100	kΩ nF	
			Source Impedance				200	W	
TxC	UEM	Helgo	Voltage	Min Max	2.4		0.1	V	Transmitter power level and ramping control
			Source Impedance				200	W	
			Resolution		10			bits	
RFTemp	Helgo	UEM	Voltage at -20oC		1,57		V	Temperature sensor of RF.	

			Voltage at +25oC		1,7			
			Voltage at +60oC		1,79			
IPA1 / IPA2	UEM	PA	Output Voltage	0		2.7	V	PA final stage quiescent current adjustment
			Current range	0		5	mA	

External Signals and Connections

Keyboard (board-to-board) Connector

Pin	Signal	Min.	Nom	Max	Condition	Note
1	GND		0V			
2	VLED+		VBAT 7.5V		LED off LED on	Supply Voltage for Keyboard LEDs
3	ROW(4)	0.7xVIO 0		1.8V 0.3xVIO	High Low	Keyboard matrix row 4
4	ROW(3)	0.7xVIO 0		VIO 0.3xVIO	High Low	Keyboard matrix row 3
5	COL(2)	0.7xVIO 0		VIO 0.3xVIO	High Low	Keyboard matrix column 2
6	ROW(2)	0.7xVIO 0		VIO 0.3xVIO	High Low	Keyboard matrix row 2
7	COL(1)	0.7xVIO 0		VIO 0.3xVIO	High Low	Keyboard matrix column 1
8	ROW(0)	0.7xVIO 0		VIO 0.3xVIO	High Low	Keyboard matrix row 0
9	VLED1-		0V 1.9V		LED off LED on	LED Katode Voltage
10	ROW(1)	0.7xVIO 0		VIO 0.3xVIO	High Low	Keyboard matrix row 1
11	COL(3)	0.7xVIO 0		VIO 0.3xVIO	High Low	Keyboard matrix column 3
12	COL(4)	0.7xVIO 0		VIO 0.3xVIO	High Low	Keyboard matrix column 4
13	VLED2-		0V 1.9V		LED off LED on	LED Katode Voltage
14	GND		0V			

15	VLED3-		0V 1.9V		LED off LED on	LED Katode Voltage
16	GND		0V			

LCD Connector (Board to Board)

Table 1: LCD Connector (Board to Board)

Pin	Signal	Min	Nom	Max	Condition	Note
1	VDDI	1.72V	1.8V	1.88V		Logic voltage supply Connected to VIO
2	XRES	0.7*VDDI 0		VDDI 0.3*VDDI	Logic '1' Logic '0'	Reset Active low
		1us			t _{rw}	Reset active
3	SDA	0.7*VDDI 0		VDDI 0.3*VDDI	Logic '1' Logic '0'	Serial data
		100ns			t _{sds}	Data setup time
		100ns			t _{sdh}	Data hold time
4	SCLK	0.7*VDDI 0		VDDI 0.3*VDDI 6.5MHz	Logic '1' Logic '0' Max frequency	Serial clock input
		250ns			t _{scyc}	Clock cycle
		100ns			t _{shw}	Clock high
		100ns			t _{slw}	Clock low
5	CXS	0.7*VDDI 0		VDDI 0.3*VDDI	Logic '1' Logic '0'	Chip select Active low
		60ns			t _{css}	CXS low before SCLK rising edge
		100ns			t _{csh}	CXS low after SCLK rising edge

6	VDD	2.70V	2.78V	2.86V		Supply Voltage. Connected to VFLASH1
7	NC					Not Connected
8	GND		0V			Ground
9	VLED-		0V 0.525V		LED off LED on	Feedback Voltage to LED Driver
10	VLED+		0V 7V		LED off LED on	Supply Voltage for LEDs

DC Connector

Pin	Signal	Min.	Nom	Max	Condition	Note
1	VCHAR		11.1V _{peak}	16.9 V _{peak} 7.9 V _{RMS} 1.0 A _{peak}	Standard charger	Charger positive input
		7.0 V _{RMS}	8.4 V _{RMS}	9.2 V _{RMS} 850 mA	Fast charger	
2	CHGND		0			Charger ground

Bottom Connector

Bottom connector, or the system connector is of type Pop-Port (TM)

Figure 4: Bottom connector pinout

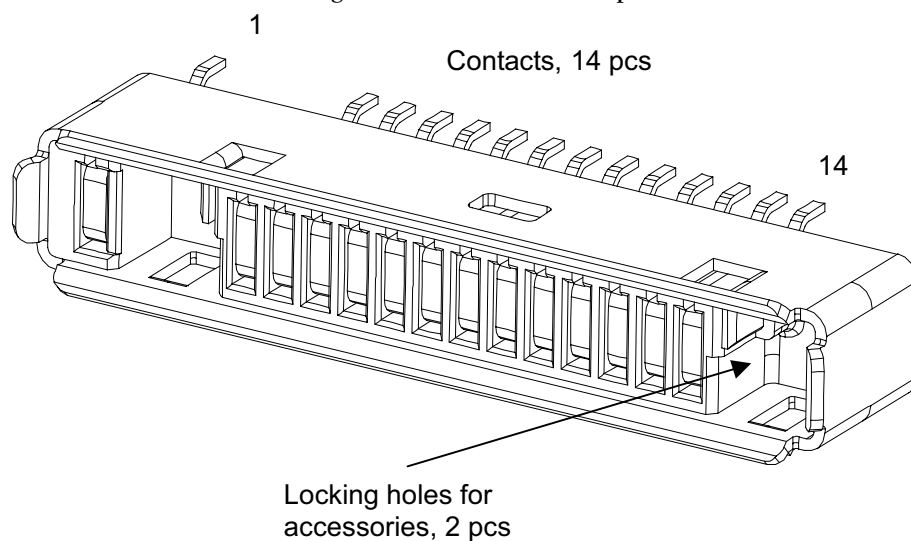

Bottom connector pins and signals:

Pin/ Signal name	Signal description	Spectral range	Voltage / Current levels	Max or nominal serial impedance	Note
1	CHARGE	V Charge	DC	0-9 V / 0.85 A	
2	GND	Charge GND		0.85 A	(PWB + conn.)
3	ACI	ACI	1 kbit/s	Dig 0 / 2.78V	Insertion & removal detection
4	VOUT	DC out	DC	2.78V / 70mA	(PWB + conn.) 200mW
5	NC				Not connected
6	FBUS RX		FBUS 115kbit	0 / 2.78V	
7	FBUS TX		FBUS 115kbit	0 / 2.78V	
8	GND	Data GND			
9	XMIC N	Audio in	300 - 8k	1Vpp & 2.78V	Ext. Mic Input
10	XMIC P	Audio in	300 - 8k	1Vpp & 2.78V	Ext. Mic Input
11	HSEAR N	Audio out	20 - 20k	1Vpp	Ext. audio out (left)
12	HSEAR P	Audio out	20 - 20k	1Vpp	Ext. audio out (left)
13	HSEAR R N	Audio out	20 - 20k	1Vpp	Ext. audio out (right)
14	HSEAR R P	Audio out	20 - 20k	1Vpp	Ext. audio out (right)

SIM connector

Pin	Name	Parameter	Min.	Typ	Max	Unit	Notes
1	VSIM	1.8V SIM Card	1.6	1.8	1.9	V	Supply voltage
		3V SIM Card	2.8	3.0	3.2	V	
2	SIMRST	1.8V SIM Card	$0.9 \times VSIM$ 0		$VSIM$ $0.15 \times VSIM$	V	SIM reset (output)
		3V SIM Card	$0.9 \times VSIM$ 0		$VSIM$ $0.15 \times VSIM$	V	
3	SIMCLK	Frequency		3.25		MHz	SIM clock
		Trise/Tfall			50	ns	
		1.8V Voh 1.8V Vol	$0.9 \times VSIM$ 0		$VSIM$	V	
		3V Voh 3V Vol	$0.9 \times VSIM$ 0		$VSIM$	V	
4	DATA	1.8V Voh 1.8V Vol	$0.9 \times VSIM$ 0		$VSIM$ $0.15 \times VSIM$	V	SIM data (output)
		3V Voh 3V Vol	$0.9 \times VSIM$ 0		$VSIM$ $0.15 \times VSIM$		
		1.8V Vih 1.8V Vil	$0.7 \times VSIM$ 0		$VSIM$ $0.15 \times VSIM$	V	SIM data (input) Trise/Tfall max 1us
		3V Vil 3V Vil	$0.7 \times VSIM$ 0		$VSIM$ $0.15 \times VSIM$		
5	NC						Not connected
6	GND	GND	0		0	V	Ground

Internal Signals and Connections

Internal microphone

Signal		Min.	Nom	Max	Condition	Note
MICP			200mV _{pp}	AC	2.2kΩ to MIC1B	MICP
	2.0 V	2.1 V	2.25 V	DC		
MICN	2.0V	2.1V	2.25V	DC		MICN

Internal speaker

Signal		Min.	Nom	Max	Condition	Note
EARP	0.75V	0.8V	2.0 V _{pp} 0.85V	AC DC	Differential output (V _{diff} = 4.0 V _{pp})	EARP
EARN	0.75V	0.8V	2.0 V _{pp} 0.85V	AC DC		EARN

Integrated HF speaker

Signal		Min.	Nom	Max	Condition	Note
IHFP	0.75V	0.8V	2.0 V _{pp} 0.85V	AC DC	Differential output (V _{diff} = 4.0 V _{pp})	IHFP
IHFN	0.75V	0.8V	2.0 V _{pp} 0.85V	AC DC		IHFN

Baseband Functional Description

Modes of Operation

1A0 baseband has six different functional modes:

- No supply
- Back-up
- Acting Dead
- Active
- Sleep
- Charging

No Supply

In *NO_SUPPLY* mode, the phone has no supply voltage. This mode is due to disconnection of main battery and backup battery or low battery voltage level in both of the batteries.

Phone is exiting from *NO_SUPPLY* mode when sufficient battery voltage level is detected. Battery voltage can rise either by connecting a new battery with $V_{BAT} > V_{MSTR+}$ or by connecting charger and charging the battery above V_{MSTR+} .

Back-up

In *BACK_UP* mode the backup battery has sufficient charge but the main battery can be disconnected or empty ($V_{BAT} < V_{MSTR}$ and $V_{BACK} > V_{BU_{COFF}}$).

VRTC regulator is disabled in *BACK_UP* mode. VRTC output is supplied without regulation from backup battery (VBACK). All the other regulators are disabled in *BACK_UP* mode.

Acting Dead

If the phone is off when the charger is connected, the phone is powered on but enters a state called "*Acting Dead*". To the user, the phone acts as if it was switched off. A battery charging alert is given and/or a battery charging indication on the display is shown to acknowledge the user that the battery is being charged.

Active

In the *Active* mode the phone is in normal operation, scanning for channels, listening to a base station, transmitting and processing information. There are several sub-states in the active mode depending on if the phone is in burst reception, burst transmission, if DSP is working etc.

One of the sub-states of the active mode is FM radio on state. In that case, Audio Amplifier and FM radio are powered on. FM radio circuitry is controlled by the MCU and 13MHz-reference clock is generated in the UPP. VFLASH2 regulator is operating.

In *Active* mode the RF regulators are controlled by SW writing into EM's registers wanted settings: VR1A can be enabled or disabled. VR2 can be enabled or disabled and its output voltage can be programmed to be 2.78V or 3.3V. VR4 -VR7 can be enabled, disabled, or forced into low quiescent current mode. VR3 is always enabled in *Active* mode.

Sleep Mode

Sleep mode is entered when both MCU and DSP are in stand-by mode. Sleep is controlled by both processors. When SLEEPX low signal is detected UEM enters SLEEP mode. VCORE, VIO and VFLASH1 regulators are put into low quiescent current mode. All the RF regulators are disabled in SLEEP. When SLEEPX=1 detected UEM enters ACTIVE mode and all functions are activated.

The sleep mode is exited either by the expiration of a sleep clock counter in the UEM or by some external interrupt, generated by a charger connection, key press, headset connection etc.

In sleep mode VCTCXO is shut down and 32 kHz sleep clock oscillator is used as reference clock for the baseband.

Charging

Charging can be performed in any operating mode.

RH-20 supports the standard NMP charger interface.

Supported chargers are ACP-7, ACP-8, ACP-12, LCH-12 and LCH-9.

Charging is controlled by the UEM ASIC and external components are needed for EMC, reverse polarity and transient protection of the input to the baseband module. The charger connection is through the system connector interface. The RH-20 baseband is designed to support DCT3 chargers from an electrical point of view. Both 2- and 3-wire type chargers are supported.

The operation of the charging circuit has been specified in such a way as to limit the power dissipation across the charge switch and to ensure safe operation in all modes.

Battery

780 mAh Li-ion battery pack BLD-3 is used in RH-20.

Description	Value
Nominal discharge cut-off voltage	3.1V
Nominal battery voltage	3.6V
Nominal charging voltage	4.2V
Maximum charger output current	850 mA
Minimum charger output current	200 mA

Pin numbering of battery pack

Signal name	Pin number	Function
VBAT	1	Positive battery terminal
BSI	2	Battery capacity measurement (fixed resistor inside the battery pack)
BTEMP	3	Battery temperature measurement (measured by ntc resistor inside pack)
GND	4	Negative/common battery terminal

Figure 5: BLD-3 battery pack pin order

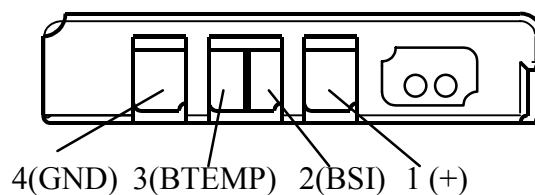

Power Up and Reset

Power up and reset is controlled by the UEM ASIC. RH-20 baseband can be powered up in following ways:

- Press power button which means grounding the PWRONX pin on UEM
- Connect the charger to the charger input
- Supply battery voltage to the battery pin.
- RTC Alarm, the RTC has been programmed to give an alarm

After receiving one of the above signals, the UEM counts a 20ms delay and then enters its reset mode. The watchdog starts up, and if the battery voltage is greater than $V_{\text{coeff+}}$ a 200ms delay is started to allow references etc. to settle. After this delay elapses the VFLASH1 regulator is enabled.

500us later VR3, VANA, VIO and VCORE are enabled. Finally the PURX line is held low for 20 ms. This reset, PURX, is fed to the baseband ASIC UPP, resets are generated for the DSP and the MCU. During this reset phase the UEM forces the VCXO regulator on regardless of the status of the sleep control input signal to the UEM.

The sleep signal from the ASIC is used to reset the flash during power up and to put the flash in power down during sleep. All baseband regulators are switched on at the UEM power on except for the SIM regulator that is controlled by the MCU. The UEM internal watchdog is running during the UEM reset state, with the longest watchdog time selected. If the watchdog expires, the UEM returns to power off state. The UEM watchdog is internally acknowledged at the rising edge of the PURX signal in order to always

give the same watchdog response time to the MCU.

Power Up with PWR key

When the Power on key is pressed the UEM enters the power up sequence as described in the previous paragraph. Pressing the power key causes the PWRONX pin on the UEM to be grounded. The UEM PWRONX signal is not part of the keypad matrix. The power key is only connected to the UEM. This means that when pressing the power key an interrupt is generated to the UPP that starts the MCU.

The MCU then reads the UEM interrupt register and notice that it is a PWRONX interrupt. The MCU now reads the status of the PWRONX signal using the UEM control bus, CBUS. If the PWRONX signal stays low for a certain time the MCU accepts this as a valid power on state and continues with the SW initialization of the baseband. If the power on key does not indicate a valid power on situation, the MCU powers off the baseband.

Power Up when Charger is connected

In order to be able to detect and start charging in a case where the main battery is fully discharged (empty) and hence UEM has no supply (NO_SUPPLY or BACKUP mode of UEM) charging is controlled by START-UP CHARGING circuitry.

Whenever VBAT level is detected to be below master reset threshold (VMSTR-) charging is controlled by START_UP charge circuitry. Connecting a charger forces VCHAR input to rise above charger detection threshold, VCHDET+.

By detection start-up charging is started. UEM generates 100mA constant output current from the connected charger's output voltage. As battery charges its voltage rises, and when VBAT voltage level higher than master reset threshold limit (VMSTR+) is detected START_UP charge is terminated.

Monitoring the VBAT voltage level is done by charge control block (CHACON). MSTRX='1' output reset signal (internal to UEM) is given to UEM's RESET block when VBAT>VMSTR+ and UEM enters into reset sequence described in section Power Up and Reset.

If VBAT is detected to fall below VMSTR- during start-up charging, charging is cancelled. It will restart if new rising edge on VCHAR input is detected (VCHAR rising above VCHDET+).

Power Up when Battery is connected

Baseband can be powered up by connecting battery with sufficient voltage. Battery voltage has to be over UEM internal comparator threshold level, Vcoff+. Battery low limit is specified in Table 2. Battery Voltage Range. When battery voltage is detected, UEM enters to reset sequence as described in section Power Up and Reset

Phone can be powered up to LOCAL mode by setting BSI resistor 560Ω. This causes MCU to wake up directly when battery voltage is supplied.

RTC Alarm Power Up

If phone is in power off mode when RTC alarm occurs the wake up procedure is as

described in section Power Up and Reset. After baseband is powered on, an interrupt is given to MCU. When RTC alarm occurs during power on state the interrupt for MCU is generated.

A/D Channels

The UEM contains the following A/D converter channels that are used for several measurement purpose. The general slow A/D converter is a 10 bit converter using the UEM interface clock for the conversion. An interrupt will be given at the end of the measurement.

The UEM's 11-channel analog to digital converter is used to monitor charging functions, battery functions, user interface and RF functions.

The monitored battery functions are battery voltage (VBATADC), battery type (BSI) and battery temperature (BTEMP) indication.

The battery type is recognized through a resistive voltage divider. In phone there is a 100k Ω pull up resistor in the BSI line and the battery has a pull down resistor in the same line. Depending on the battery type the pull down resistor value varies. The battery temperature is measured equivalently except that the battery has a NTC pull down resistor in the BTEMP line.

KEYB1&2 inputs are used for keyboard scanning purposes. These inputs are also routed internally to the miscellaneous block.

The monitored RF functions are PATEMP and VCXOTEMP detection. PATEMP input is used to measure temperature of the RFIC, the Helgo.

FM Radio

The FM radio in the transceiver RH-20 is a single chip electronically tuned FM stereo radio with fully integrated IF selectivity and demodulation. The FM radio is completely adjustment free.

It can be tuned the European, US and Japanese FM bands.

The channel tuning and bus data are controlled by UPP. A variable capacitance diode, two coils and some resistors and capacitors are the external components for the FM radio.

The audio frequency is fed via UEM to a headset of the phone. The FM radio antenna is implemented in a cable of the headset.

Figure 6: FM radio

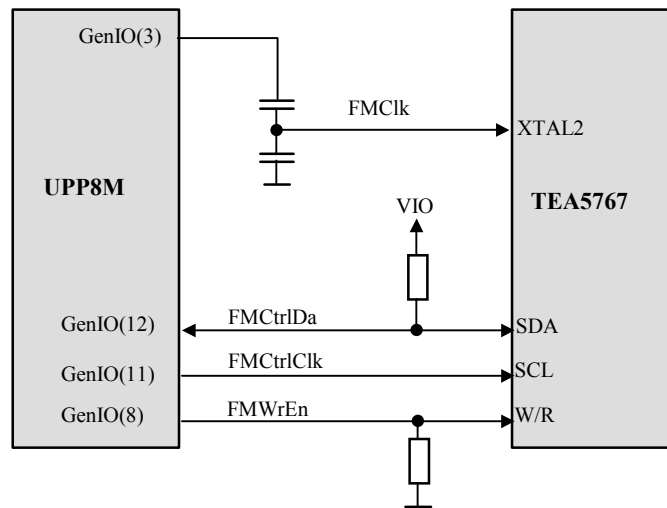

Camera

CIF camera module will be used in RH-20. Camera is connected to baseband (UPP) through HW accelerator IC. External 1.8V regulator is used as a power supply (VDIG) for camera module and HW accelerator together with VFLASH2.

Figure 7: Camera connections to baseband

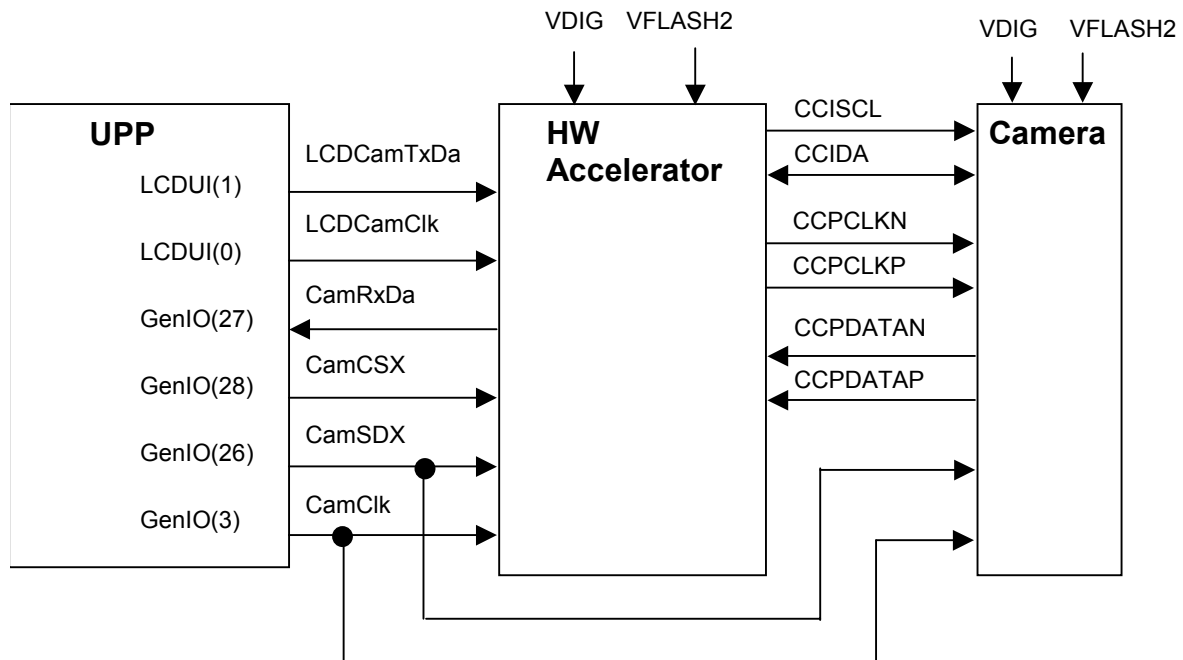

CIF camera has a resolution of 352 x 288. Pixel size is 5.6um x 5.6um. Both camera and HW accelerator support sleep functionality in order to minimize the current consumption.

IR Module

The IR interface when using transceiver with 1.8V I/O is designed into the UPP. The IR link supports speeds from 9600 bit/s to 1.152 MBit/s up to distance of 80 cm. Transmission over the IR is half-duplex.

SIM Interface

UEM contains the SIM interface logic level shifting. SIM interface can be programmed to support 3V and 1.8V SIMs. SIM supply voltage is selected by a register in the UEM. It is only allowed to change the SIM supply voltage when the SIM IF is powered down.

The SIM power up/down sequence is generated in the UEM. This means that the UEM generates the RST signal to the SIM. Also the SIMCardDet signal is connected to UEM. The card detection is taken from the BSI signal, which detects the removal of the battery.

The SIM interface is powered up when the SIMCardDet signal indicates "card in". This signal is derived from the BSI signal.

Parameter	Variable	Min.	Typ	Max	Unit
SIMCARDet, BSI comparator Threshold	Vkey	1.94	2.1	2.26	V
SIMCARDet, BSI comparator Hysteresis (1)	Vsimhyst	50	75	100	mV

The entire SIM interface locates in two chips: UPP and UEM.

The SIM interface in the UEM contains power up/down, port gating, card detect, data receiving, ATR-counter, registers and level shifting buffers logic. The SIM interface is the electrical interface between the Subscriber Identity Module Card (SIM Card) and mobile phone (via UEM device).

The data communication between the card and the phone is asynchronous half duplex. The clock supplied to the card is in GSM system 1.083 MHz or 3.25 MHz.

Figure 8: SIM interface RH-20

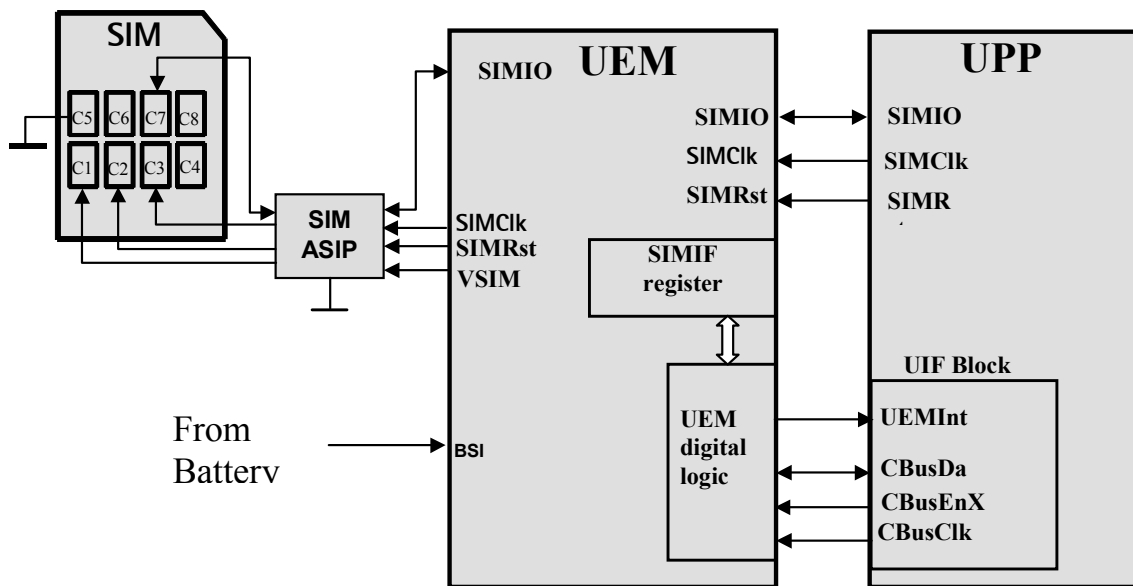

ACI

ACI is a point-to-point, bi-directional serial bus. ACI has two main features: 1) The insertion and removal detection of an accessory device 2) acting as a data bus, intended mainly for control purposes. A third function provided by ACI is to identify and authenticate the specific accessory which is connected to the System interface.

External Accessory Regulator

An external LDO Regulator exists for accessory power supply purposes. All ACI-accessories require this power supply. Regulator input is connected to battery voltage VBAT and output is connected to Vout pin in the system connector. Regulator is controlled via UPP (On/Off-function).

Accessory Regulator Signals

Signal	Min.	Nom	Max	Note
Vout	2.70V	2.78	2.86V	$I_{max} = 150mA$
GenIO(0)	1.4	1.8	1.88 0.6	High (ON) Low (OFF)

Figure 9: External Accessory regulation

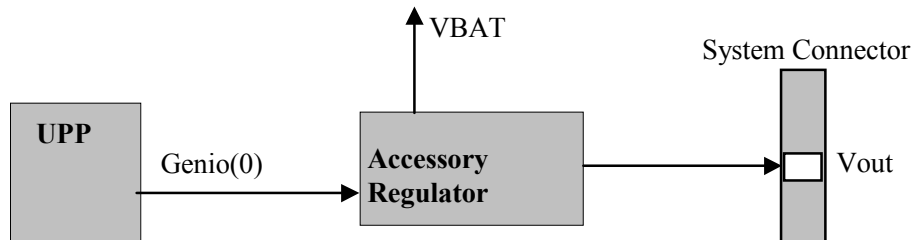

External Audio

RH-20 is designed to support fully differential external audio accessory connection by using Pop-Port [TM] system connector. Pop-Port [TM] connector has serial data bus called ACI (Accessory Control Interface) for accessory insertion and removal detection and identification and authentication. ACI line is also used for accessory control purposes. See section ACI, Accessory Control Interface. Audio support from Pop-Port [TM] system connector:

4-wire fully differential stereo audio (used also FM-radio antenna connection)

2-wire differential mic input

External Microphone Connection

The external microphone input is fully differential and lines are connected to the UEM microphone input MIC2P/N. The UEM (MICB2) provides bias voltage. Microphone input lines are ESD protected.

Creating a short circuit between the headset microphone signals generates the hook signal. When the accessory is not connected, the UEM resistor pulls up the HookInt signal. When the accessory is inserted and the microphone path is biased the HookInt signal decreases to 1.8V due to the microphone bias current flowing through the resistor. When the button is pressed the microphone signals are connected together, and the HookInt input will get half of micbias dc value 1.1 V. This change in DC level will cause the Hook-

Int comparator output to change state, in this case from 0 to 1. The button can be used for answering incoming calls but not to initiate outgoing calls.

Figure 10: External microphone connection

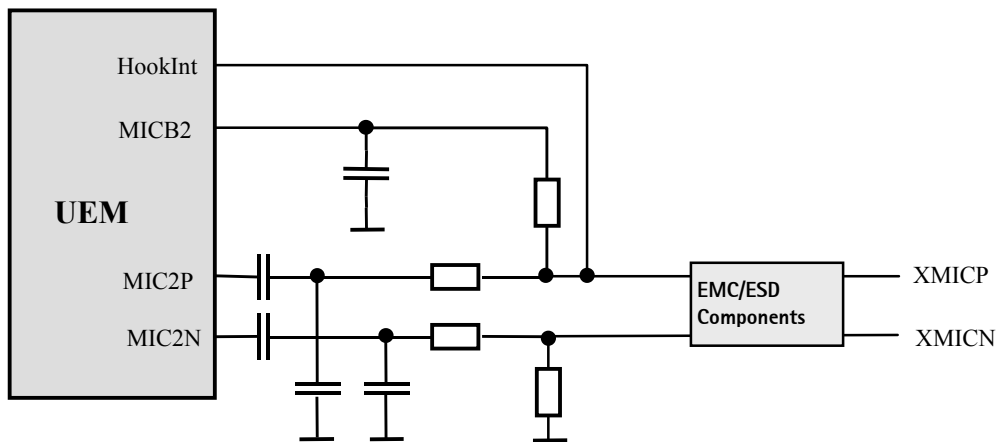

External Earphone Connections

Headset implementation uses separate microphone and earpiece signals. The accessory is detected by the HeadInt signal when the headset is inserted (see section ACI, Accessory Control Interface).

Figure 11: External Earphone & IHF Connections

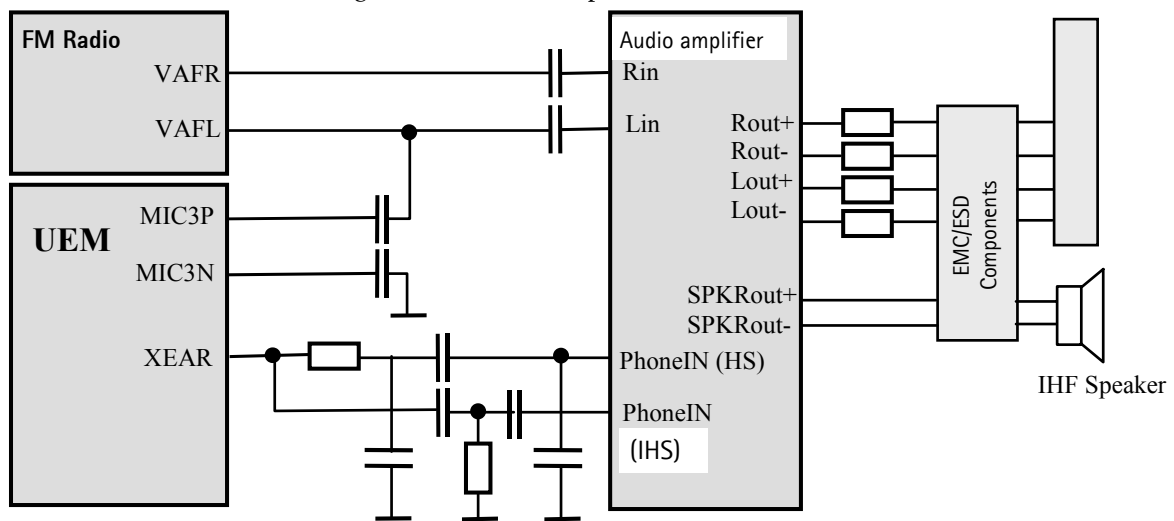

When the accessory is inserted and the microphone path is biased the HookInt signal decreases to 1.8V due to the microphone bias current flowing through the resistor. When the button is pressed the microphone signals are connected together, and the HookInt input will get half of micbias dc value 1.1 V. This change in DC level will cause the HookInt comparator output to change state, in this case from 0 to 1. The button can be used for answering incoming calls but not to initiate outgoing calls.

Internal Audio

IHF Speaker & Stereo Audio Amplifier

Integrated Hands Free Speaker, 16mm MALT, is used to generate speech audio, alerting and warning tones in RH-20. Audio amplifier is controlled by the UPP. Speaker capsule is mounted in the C-cover. Spring contacts are used to connect the IHF Speaker contacts to the main PWB.

Figure 12: IHF speaker and amplifier

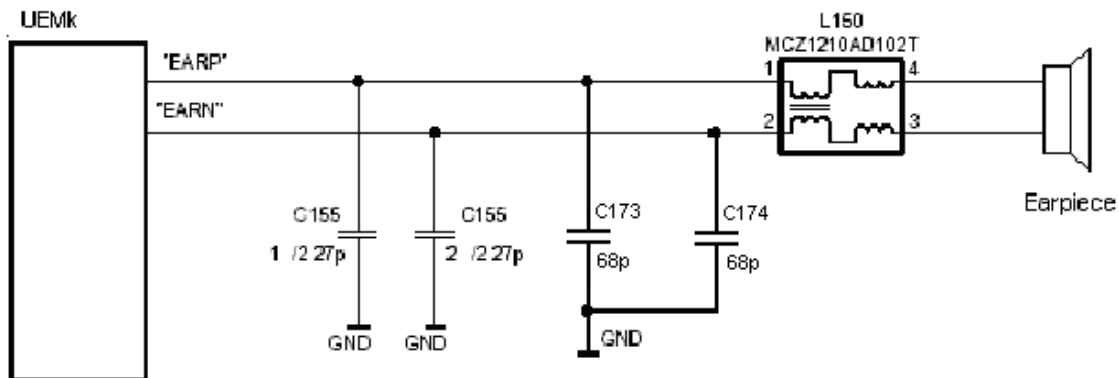

Internal Microphone

The internal microphone capsule is mounted to in the UI-frame. Microphone is omni directional and it's connected to the UEM microphone input MIC1P/N. The microphone input is asymmetric and the UEM (MICB1) provides bias voltage. The microphone input on the UEM is ESD protected. Spring contacts are used to connect the microphone to the main PWB.

Figure 13: Internal microphone

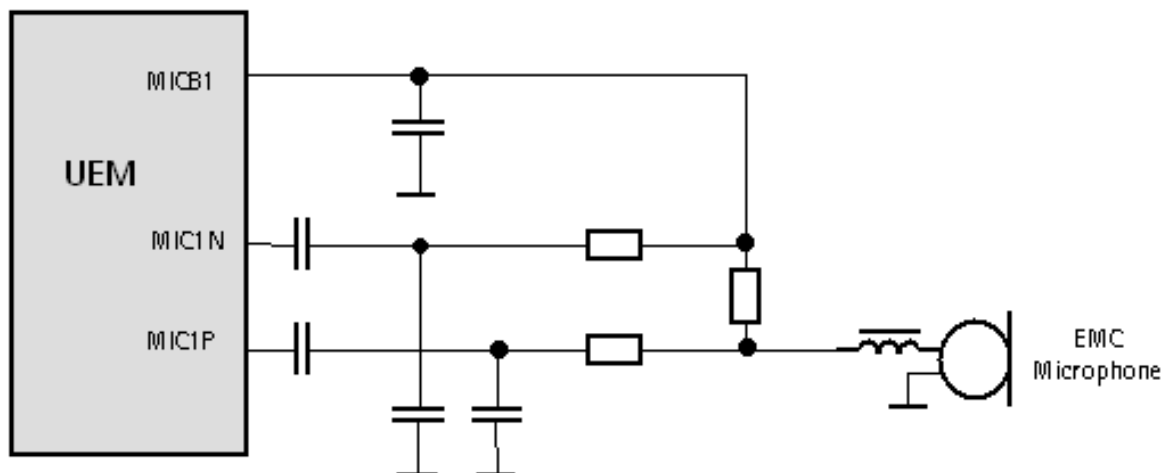

Internal Speaker

The internal earpiece is a dynamic earpiece with impedance of 32 ohms. The earpiece must be low impedance one since the sound pressure is to be generated using current and not voltage as the supply voltage is restricted to 2.7V. The earpiece is driven directly by the UEM and the earpiece driver in UEM is a bridge amplifier. In RH-20 8mm PICO

type earpiece is used.

Figure 14: Internal speaker

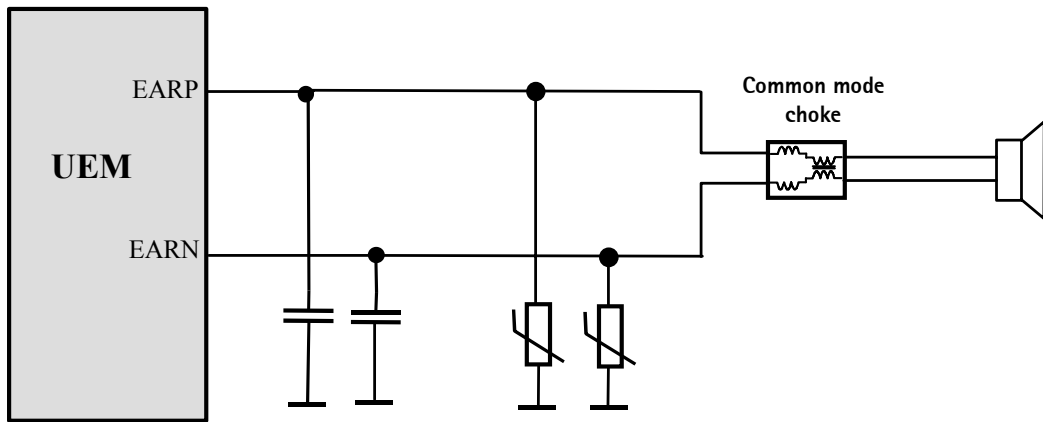

IHF Speaker & Stereo Audio Amplifier

Integrated Hands Free Speaker, 16mm MALT, is used to generate speech audio, alerting and warning tones in RH-20. Audio amplifier is controlled by the UPP. Speaker capsule is mounted in the C-cover. Spring contacts are used to connect the IHF Speaker contacts to the main PWB.

Figure 15: Digital Interface of Audio Amplifier

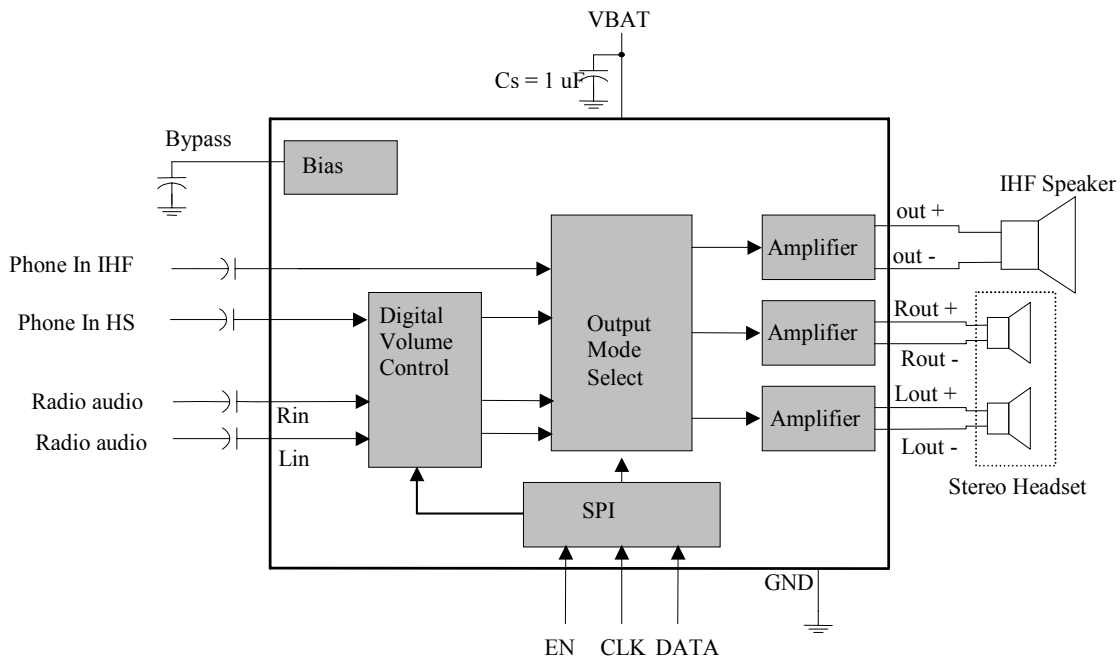

Memory Block

For the MCU UPP includes ROM, 8 kbytes, that is used mainly for boot code of MCU. To speed up the MCU operation small 4 kbyte cache is also integrated as a part of the MCU memory interface. For program memory 8Mbit (512 x 16bit) PDRAM is integrated. RAM block can also be used as data memory and it is byte addressable. RAM is mainly for MCU purposes but also DSP has also access to it if needed.

In addition to UPP integrated RAM RH-20 baseband has also UPP external SRAM. This is implemented in combo memory (single package with stacked ICs, 128Mbit flash + 8 Mbit SRAM).

MCU code is stored into external flash memory. Size of the flash is 128Mbit (8192 x 16bit) The HDi 13 baseband supports a burst mode flash with multiplexed address/data bus. Access to the flash memory is performed as 16-bit access. The flash has Read While Write capabilities which makes the emulation of EEPROM within the flash easy.

Security

The phone flash program and IMEI codes are software protected using an external security device that is connected between the phone and a PC.

Clock distribution

Figure 16: Clock Distribution Diagram

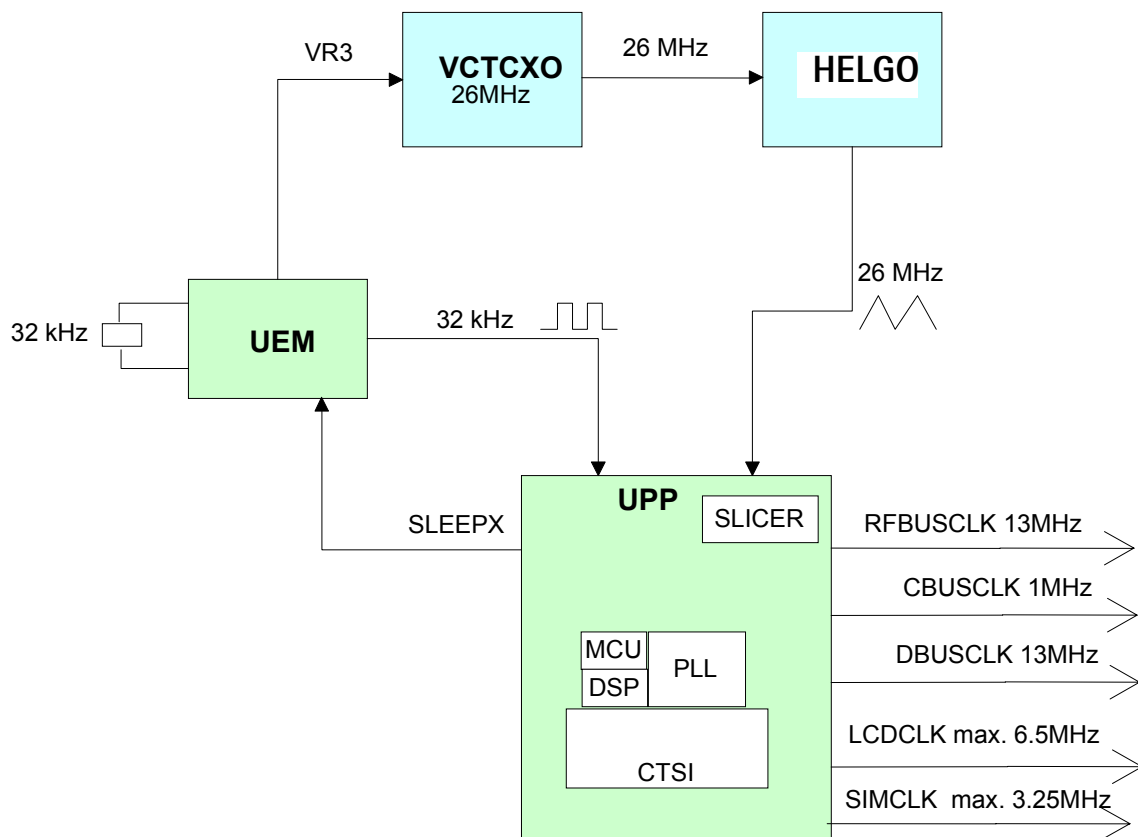

Audio Control

Figure 17: Audio block diagram RH-20

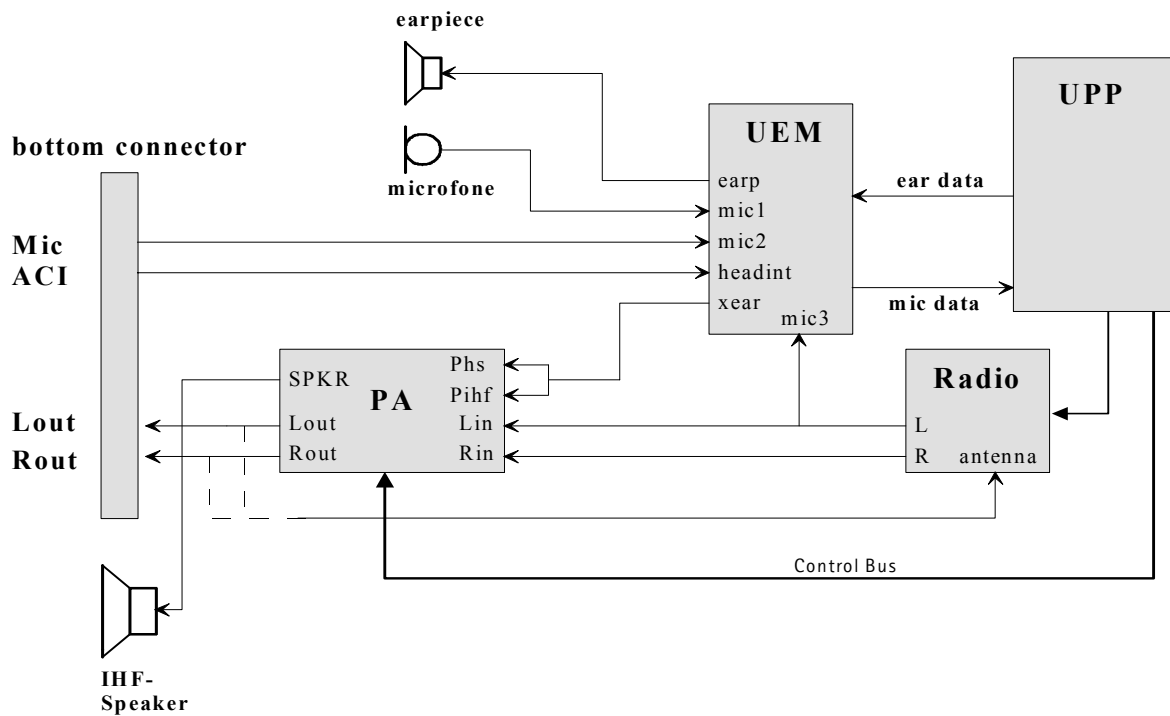

Accessory identification and Power Supply

Figure 18: Accessory identification and Power supply

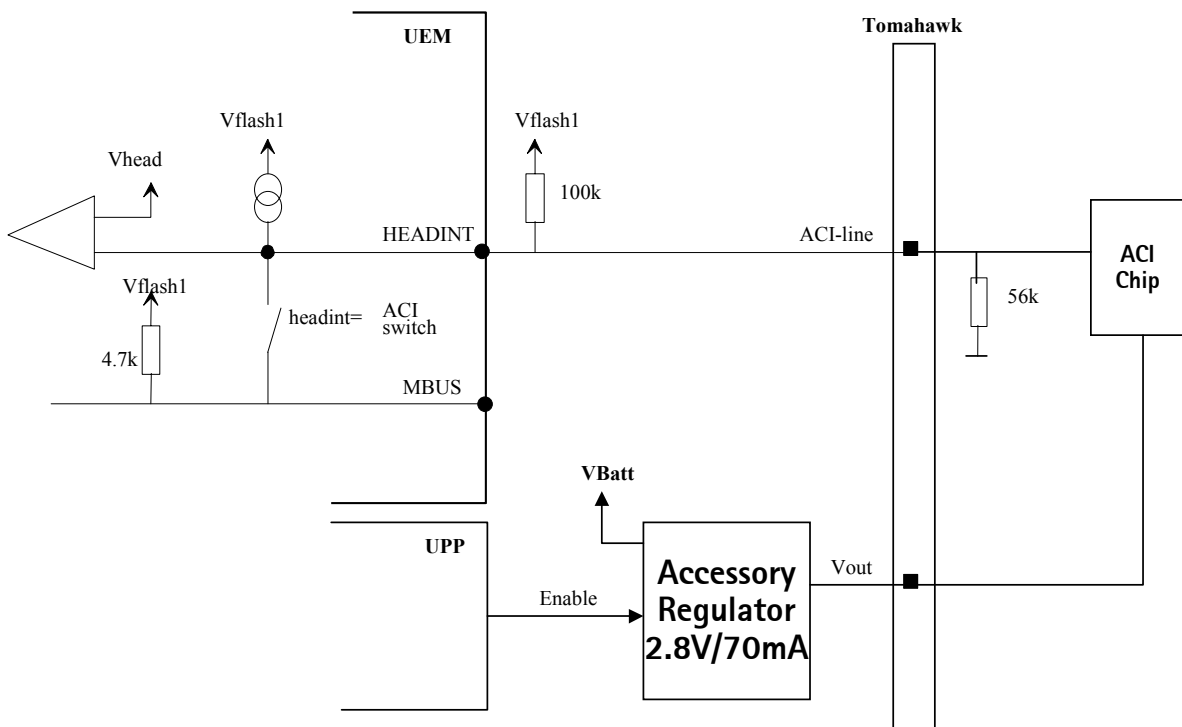

Backup Battery

Backup battery is used in case when main battery is either removed or discharged. Backup battery is used for keeping real-time clock running for minimum of 30 minutes.

Rechargeable backup battery is connected between UEM VBACK and GND. In UEM backup battery charging high limit is set to 3.2V. The cut-off limit voltage (V_{BU_{COFF-}}) for backup battery is 2.0V. Backup battery charging is controlled by MCU by writing into UEM register.

Li-Ion SMD battery type is used. The nominal capacity of the battery is 0.01 mAh.

Table 28. Backup Battery circuitry

Parameter Test conditions	Symbol	Min	Typ	Max	Units
Back-up battery voltage	VBACK	2.43		3.3	V
Back-up battery cut-off limit	V _{BU_{COFF+}}	2.04	2.10	2.16	V
	V _{BU_{COFF-}}	1.94	2.0	2.06	V
Charging voltage (VBAT ≥ 3.4V)	VBU	3.1	3.2	3.3	V
Charging current	I _{LIMVBU}	150		500	mA

RF Module Introduction

The RF module performs the necessary high frequency operations of the EGSM900/GSM1800/GSM1900 tripleband (EDGE) engine. Both the transmitter and receiver have been implemented by using direct conversion architecture which means that the modulator and demodulator operate at the channel frequency.

The core of the RF is an application-specific integrated circuit, Helgo. Another core component is a power amplifier module which includes two amplifier chains, one for EGSM900 and the other for GSM1800/GSM1900.

Other key components include

- 26 MHz VCTCXO for frequency reference
- 3420-3980 MHz SHF VCO (super high frequency voltage controlled oscillator)
- front end module comprising a RX/TX switch
- four additional SAW filters

The control information for the RF is coming from the baseband section of the engine through a serial bus, referred later on as RFBUS. This serial bus is used to pass the information about the frequency band, mode of operation, and synthesizer channel for the RF. In addition, exact timing information and receiver gain settings are transferred through the RFBUS. Physically, the bus is located between the baseband ASIC called UPP and Helgo. Using the information obtained from UPP Helgo controls itself to the required mode of operation and further sends control signals to the front end and power amplifier modules. In addition to the RFBUS there are still other interface signals for the power control loop and VCTCXO control and for the modulated waveforms.

RF circuitry is located on one side of the 8 layer PWB.

EMC leakage is prevented by using a metal cans. The RF circuits are separated to three blocks.

- FM radio.
- PA, front end module, LNA, 1900 band Rx SAWs and 900 Tx SAW.
- Helgo RF IC, VCO, VCTCXO, baluns and 1800 and 1900 Rx SAWs.

The RF transmission lines constitute of striplines and microstriplines after PA.

The baseband circuitry is located on the one side of the board, which is shielded with a metallized frame and ground plane of the UI-board.

RF Frequency Plan

RF frequency plan is shown below. The VCO operates at the channel frequency multiplied by two or four depending on the frequency band of operation. This means that the base-band modulated signals are directly converted up to the transmission frequency and the received RF signals directly down to the baseband frequency.

Figure 19: RF Frequency plan

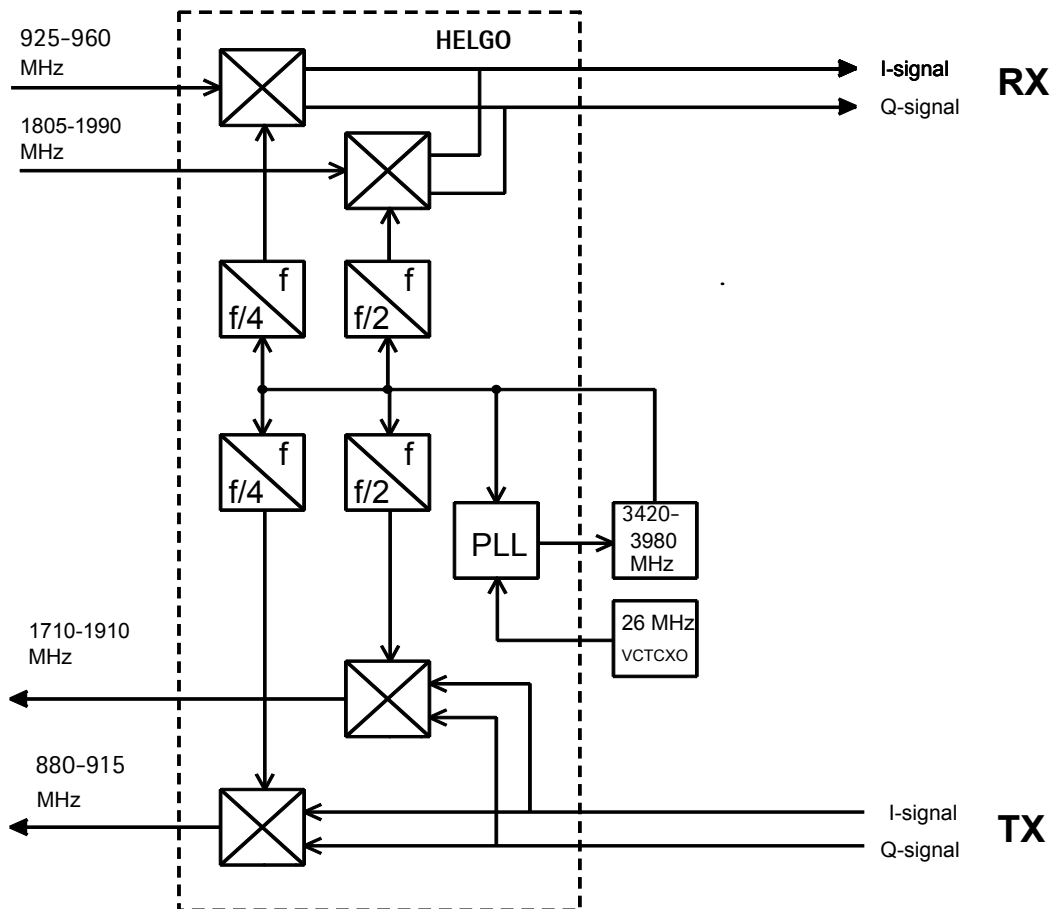

DC characteristics

Regulators

The transceiver baseband section has a multi function analog ASIC, UEM, which contains among other functions six pieces of 2.78 V linear regulators and a 4.8 V switching regulator. All the regulators can be controlled individually by the 2.78 V logic directly or through a control register. Normally, direct control is needed because of switching speed requirement: the regulators are used to enable the RF-functions which means that the controls must be fast enough.

The use of the regulators can be seen in the power distribution diagram which is presented in Figure 20, "Power distribution diagram," on page 43.

The seven regulators are named VR1 to VR7. VrefRF01 and VrefRF02 are used as the reference voltages for the Helgo, VrefRF01 (1.35V) for the bias reference and VrefRF02 (1.35V) for the RX ADC (analog-to-digital converter) reference.

The regulators (except for VR7) are connected to the Helgo. Different modes of operation can be selected inside the Helgo according to the control information coming through the RFBus.

List of the needed supply voltages

Volt. source	Load
VR1	PLL charge pump (4.8 V)
VR2	TX modulators, VPECTRL3s (ALC), driver
VR3	VCTCXO, synthesizer digital parts
VR4	Helgo pre-amps, mixers, DtoS
VR5	dividers, LO-buffers, prescaler
VR6	LNAs, Helgo baseband (Vdd_bb)
VR7	VCO
VrefRF01	ref. voltage for Helgo
VrefRF02	ref. voltage for Helgo
Vbatt	PA

Typical current consumption

The table shows the typical current consumption in different operation modes.

Operation mode	Current consumption	Notes
Power OFF	< 10 μ A	Leakage current (triple band PA)
RX, EGSM900	75 mA, peak	
RX, GSM1800/GSM1900	70 mA, peak	
TX, power level 5, EGSM900	1600 mA, peak	
TX, power level 0, GSM1800/ GSM1900	900 mA, peak	

Power Distribution

Figure 20: Power distribution diagram

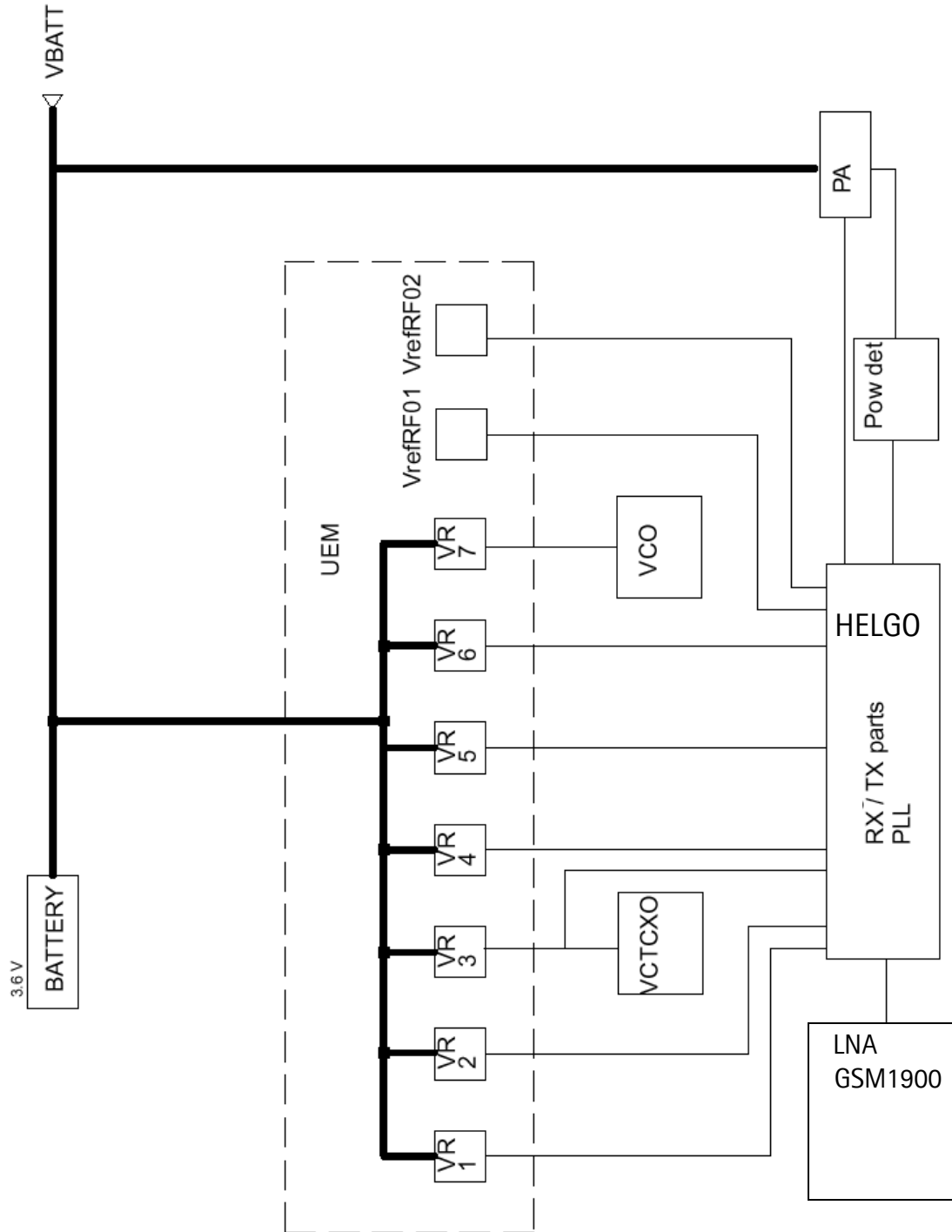

RF characteristics

Channel Numbers and Frequencies

System	Channel number	TX frequency	RX frequency	Unit
EGSM900	$0 < n \leq 124$	$F = 890 + 0.2 * n$	$F = 935 + 0.2 * n$	MHz
	$975 \leq n \leq 1023$	$F = 890 + 0.2 * (n - 1024)$	$F = 935 + 0.2 * (n - 1024)$	MHz
GSM1800	$512 \leq n \leq 885$	$F = 1710.2 + 0.2 * (n - 512)$	$F = 1805.2 + 0.2 * (n - 512)$	MHz
GSM1900	$512 \leq n \leq 810$	$F = 1850.2 + 0.2 * (n - 512)$	$F = 1930.2 + 0.2 * (n - 512)$	MHz

Main RF characteristics

Parameter	Unit and value
Cellular system	EGSM900/GSM1800/GSM1900
RX Frequency range	EGSM900: 925 ... 960 MHz GSM1800: 1805...1880 MHz GSM1900: 1930...1990 MHz
TX Frequency range	EGSM900: 880 ... 915 MHz GSM1800: 1710 ...1785 MHz GSM1900: 1850 ...1910 MHz
Duplex spacing	EGSM900: 45 MHz GSM1800: 95 MHz GSM1900: 80 MHz
Channel spacing	200 kHz
Number of RF channels	EGSM900: 174 GSM1800: 374 GSM1900: 300
Output Power	EGSM900: GSMK 5...33 dBm EGSM900: 8-PSK 5...27 dBm GSM1800: GSMK 0...30 dBm GSM1800: 8-PSK 0...26 dBm GSM1900: GSMK 0...30 dBm GSM1900: 8-PSK 0...26 dBm
Number of power levels GSMK	EGSM900: 15 GSM1800: 16 GSM1900: 16
Number of power levels 8-PSK	EGSM900: 12 GSM1800: 14 GSM1900: 14

Transmitter characteristics

Item	Values (EGSM900/GSM1800/GSM1900)
Type	Direct conversion, nonlinear, FDMA/TDMA
LO frequency range	3520...3660 MHz/3420...3570 MHz/3700...3820 MHz
Output power	GMSK 33/30/30 dBm 8-PSK 27/26/26 dBm
Gain control range	min. 30 dB
Phase error (RMS/peak), GMSK EVM (RMS/peak), 8-PSK	5 deg./20 deg. peak 10%/30%

Receiver characteristics

Item	Values, EGSM900/GSM1800/GSM1900
Type	Direct conversion, Linear, FDMA/TDMA
LO frequencies	3700...3840 MHz / 3610...3760 MHz/3860...3980 MHz
Typical 3 dB bandwidth	+/- 91 kHz
Sensitivity	min. - 102 dBm (normal condition)
Total typical receiver voltage gain (from antenna to RX ADC)	86 dB
Receiver output level (RF level -95 dBm)	230 mVpp, single-ended I/Q signals to RX ADCs
Typical AGC dynamic range	83 dB
Accurate AGC control range	60 dB
Typical AGC step in LNA	30 dB GSM1800/GSM1900 25 dB EGSM900
Usable input dynamic range	-102... -10 dBm
RSSI dynamic range	-110... -48 dBm
Compensated gain variation in receiving band	+/- 1.0 dB

RF Block Diagram

The block diagram of the RF module can be seen in Chapter on "RF Block Diagram". The detailed functional description is given in the following sections

RF Block Diagram RH-20

Figure 21: RF Block Diagram

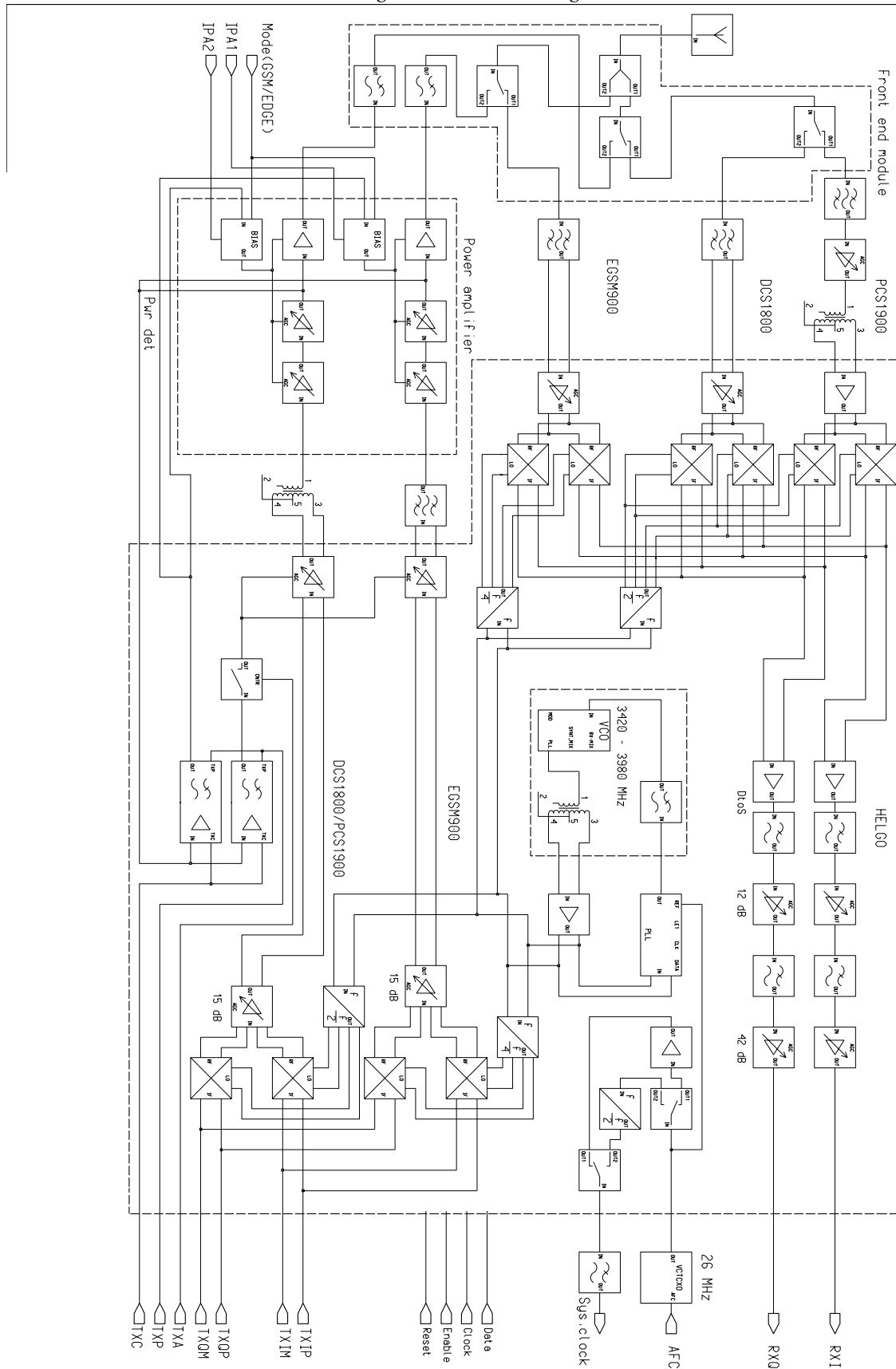

Frequency Synthesizers

The VCO frequency is locked by a PLL (phase locked loop) into a stable frequency source given by a VCTCXO which is running at 26 MHz. The frequency of the VCTCXO is in turn locked into the frequency of the base station with the help of an AFC voltage which is generated in UEM by an 11 bit D/A converter. The PLL is located in Helgo and it is controlled through the RFBus.

The required frequency dividers for modulator and demodulator mixers are integrated in Helgo.

Loop filter filters out the comparison pulses of the phase detector and generates a DC control voltage to the VCO. The loop filter determines the step response of the PLL (settling time) and contributes to the stability of the loop.

The frequency synthesizer is integrated in Helgo except for the VCTCXO, VCO, and the loop filter.

Receiver

Each receiver path is a direct conversion linear receiver. From the antenna the received RF-signal is fed to a front end module where a diplexer first divides the signal to two separate paths according to the band of operation: either lower, EGSM900 or upper, GSM1800/GSM1900 path.

Most of the receiver circuitry is included in Helgo.

Transmitter

The transmitter consists of two final frequency IQ-modulators and power amplifiers, for the lower and upper bands separately, and a power control loop. The IQ-modulators are integrated in Helgo, as well as the operational amplifiers of the power control loop. The two power amplifiers are located in a single module with power detector. In the GMSK mode the power is controlled by adjusting the DC bias levels of the power amplifiers. In EDGE mode, the power is controlled by adjusting ALC in Helgo RFIC.

Other

Other key blocks are:

- Antenna 50 ohm input
- Antenna switch module
- RX EGSM900/GSM1800 balanced output, GSM1900 single output
- TXs single 50 ohm input
- 3 control lines from the Helgo

Figure 22: Front End

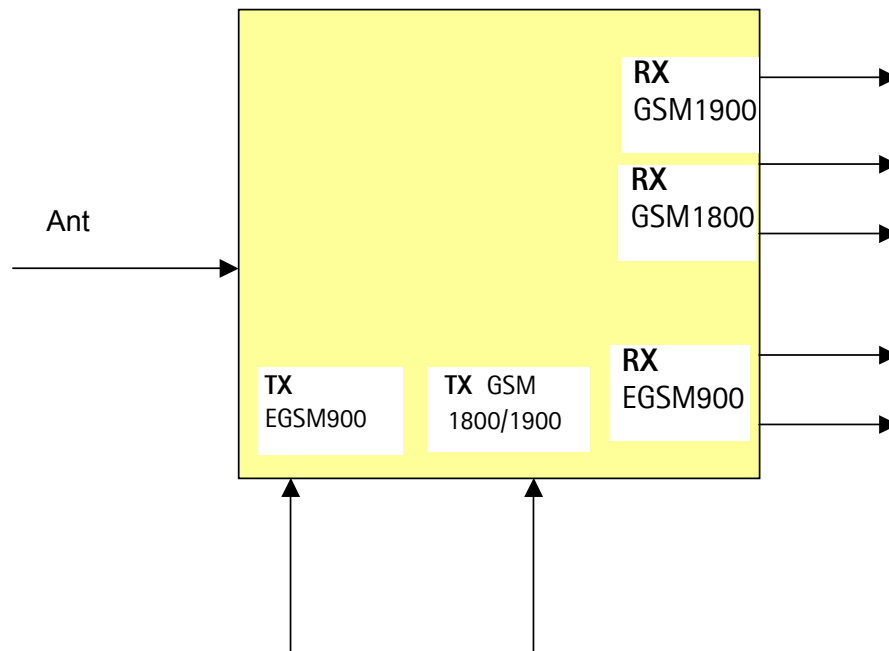

Power Amplifier

The power amplifier features include:

- 50 ohm input and output, EGSM900/GSM1800/GSM1900
- internal power detector
- EDGE mode

Figure 23: Power amplifier

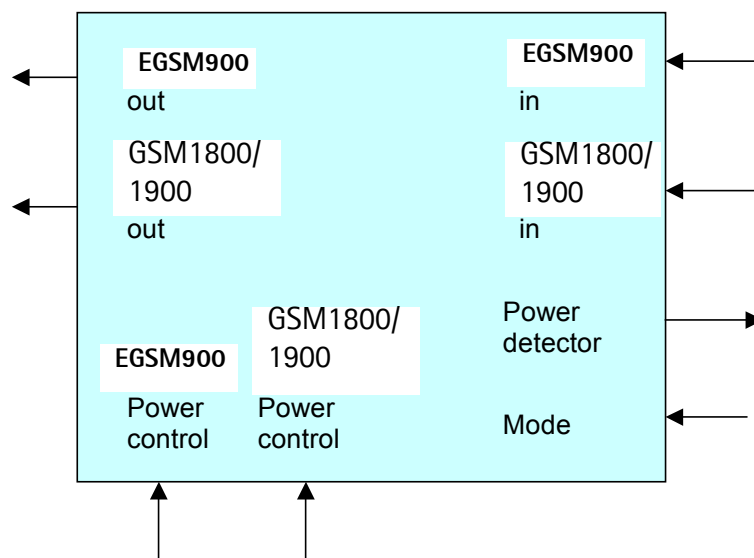

RF ASIC Helgo

The RF ASIC features include

- Package uBGA108
- Balanced I/Q demodulator and balanced I/Q modulator
- Power control operational amplifier, acts as an error amplifier
- The signal from VCO is balanced, frequencies 3420 to 3980 MHz
- EGSM900 and GSM1800 low noise amplifier (LNA) are integrated.

The Helgo can be tested by test points only.

AFC function

AFC is used to lock the transceiver's clock to the frequency of the base station.

Antenna

The RH-20 EGSM900/GSM1800/GSM1900 transceiver features an internal antenna.

User interface modules

The RH-20 UI module has a separate 4-layer UI PWB 1dm.

The user interface features a 130 x130 pixel passive matrix color STN display, 4096 colours.

The LCD display is connected to transceiver PWB by 10-pin board-to-board connector. Earpiece, microphone, IHF speaker and Vibra are connected using spring type connections. IR module and system connector are SMD devices. Keyboard (UI PWB) connects to transceiver PWB through 16-pin spring type connector.

Figure 1 below describes the user interface connections.

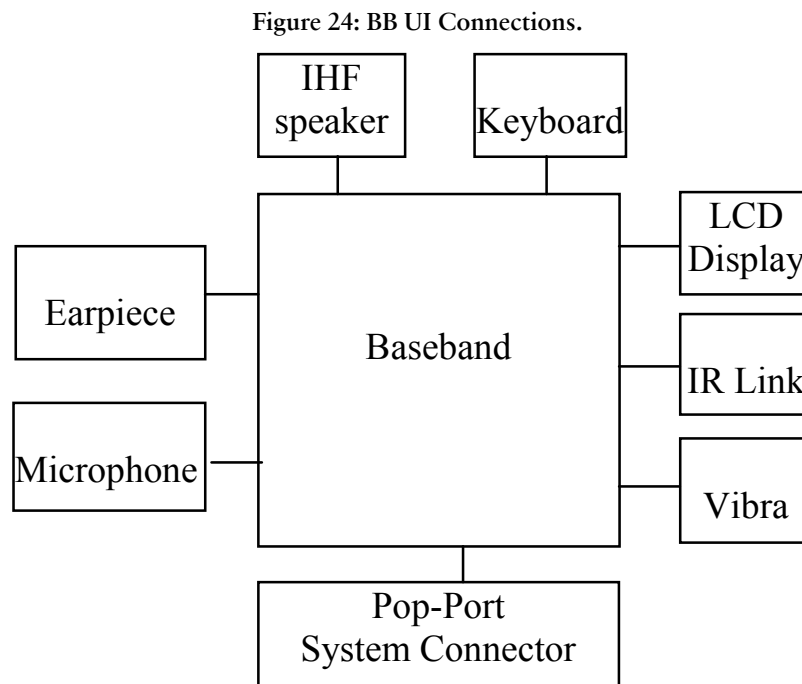

UI board 1dm

1dm includes contact pads for keypad domes and LEDs for keypad illumination. UI board is connected to main PWB through 16-pin spring type board-to-board connector. Signals of the connector are described in *External and internal signals and connections*.

Keyboard

5x4 matrix keyboard is used in RH-20. Key pressing is detected by scanning procedure. Keypad signals are connected to UPP keyboard interface. Figure 2 shows keyboard matrix in detail.

When no keys are pressed row inputs are in high state due to UPP internal pull-up resistors. Columns are set as outputs and written low. When key is pressed one row is pulled down and an interrupt is generated to MCU. After receiving interrupt MCU starts scanning procedure. All columns are first written high and then one column at the time is written low. All other columns except the one that was written low are set as inputs.

Rows are read while columns one at the time are written low. If some row is down it indicates that the key which is at the cross point of selected column and row was pressed. After key press detection registers in UPP are reset and columns are written back to low state.

Figure 25: Keyboard matrix connections.

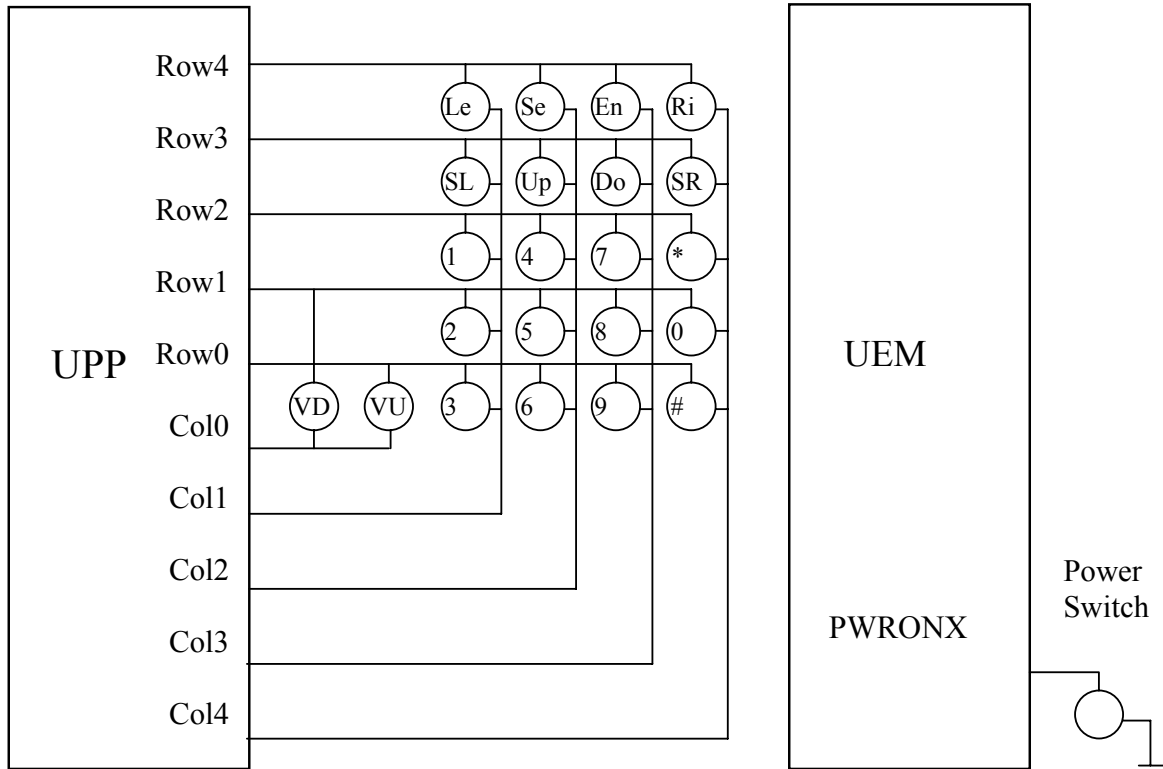

Le = Navi Left
 Se = Send
 En = End
 Ri = Navi Right

SL = Soft Left
 Up = Navi Up
 Do = Navi Down
 SR = Soft Right

VD = Volume Down
 VU = Volume Up

LCD

RH-20 has 130 x130 pixel 12bpp (bits per pixel) passive matrix color STN display. LCD is connected to transceiver PWB by 10-pin board to board connector. Interface is using 9-bit data transfer. Partial display function is implemented in the module. Table 1 shows main characteristics of RH-20 LCD.

Figure 3 shows LCD interface connections. More detailed connections are described in *External and internal signals and connections*.

Table 2: LCD Characteristics

Technology	CSTN
Display format	130 columns x 130 rows
Weight	6.7 g
Illumination Mode RAM bit data	Transflective
	"0000"...OFF (minimum voltages) Black
Numbers of colours	4096
Color dot layout	Stripe (RGB)
Dot pitch	210µm (W) x 210µm (H)
Main viewing direction	6 o'clock

Figure 26: LCD connections.

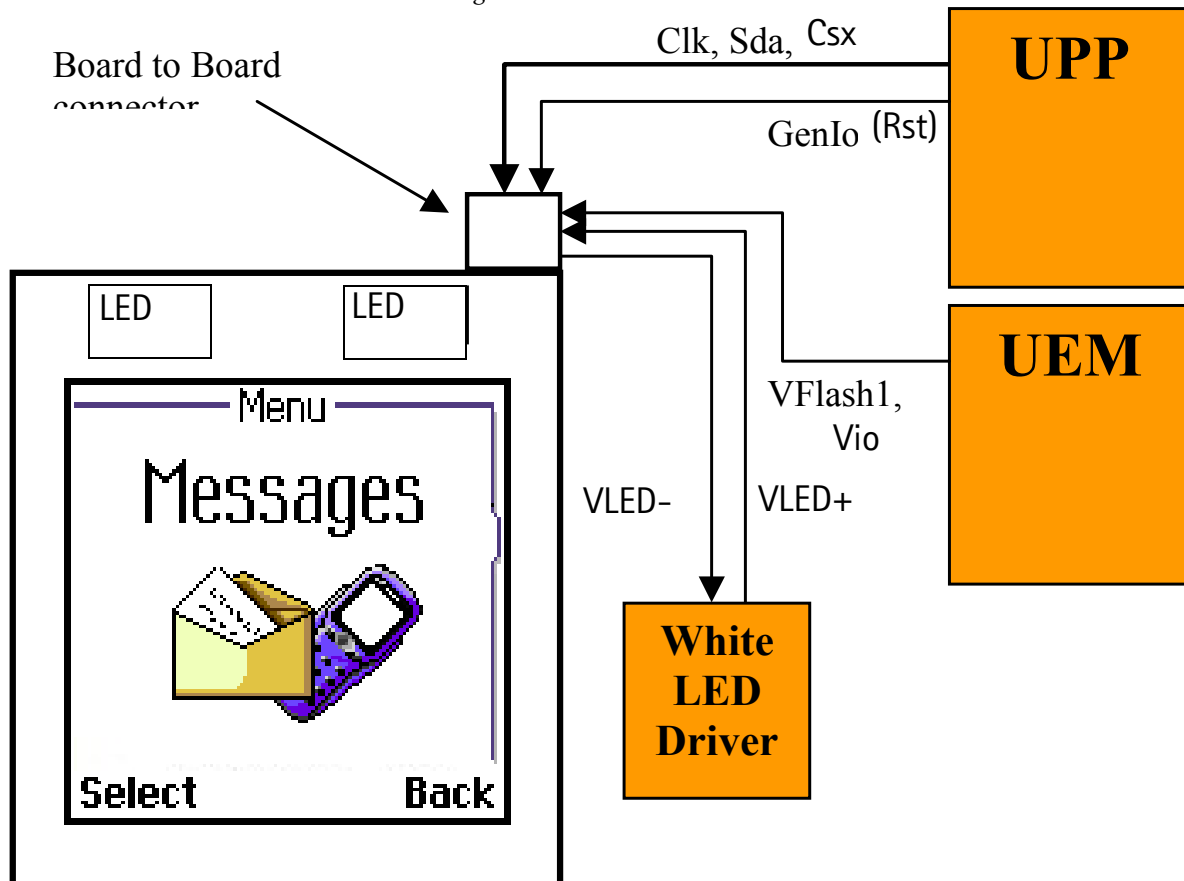

LCD & keypad illumination

In RH-20, white LEDs are used for LCD and keypad lighting. Two LEDs are used for LCD lighting and eight LEDs for keyboard. A step up DC-DC converter is used as a LED driver.

LCD LEDs are driven in serial mode to achieve stable backlight quality. This means that a constant current flow is lead through LCD LEDs. Serial resistance *R_{lcd}* is used to define the proper current. The feedback signal, *FB*, is used to control the current. A driver will increase or decrease the output voltage for LEDs to keep the current stable.

Keyboard LEDs are driven in 2 serial 4 parallel mode with one common current limiting resistor. Serial resistance *R* is used to limit the current through LEDs. The feedback signal, *FB*, from LCD LEDs controls also the current of keyboard LEDs.

Driver is controlled by UEM via DLIGHT PWM output. This signal is connected to driver EN-pin (on/off). PWM control for LEDs facilitates the 'fading' effect when LEDs are turned on/off. PWM control can also be used to limit the average current through LEDs for example in high temperature.

Figure 27: LCD & keypad illumination.

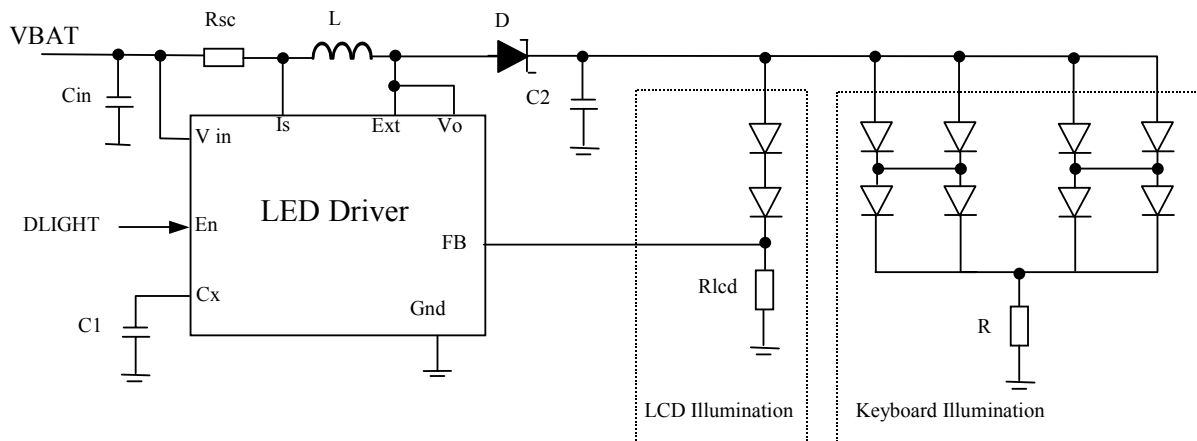

Internal earpiece

Internal earpiece is a dynamic leak tolerant type earpiece with an impedance of 320hms. The earpiece is a low impedance one since the sound pressure is to be generated using current and not voltage as supply voltage is restricted to 2.7V. The earpiece is driven differentially directly by UEM. Earpiece capsule is mounted in LCD frame assembly.

IHF

Integrated Hands Free Speaker, 16mm MALT, is used to generate speech audio, ringing and alerting tones in RH-20. Nominal impedance of the speaker is 8 Ohms. IHF speaker is driven by a stereo audio amplifier. Audio amplifier is controlled by UPP. Speaker capsule is mounted in C-cover assembly. Spring contacts are used to connect the IHF Speaker contacts to the main PWB.

Internal microphone

The internal microphone capsule is mounted in the UI-frame. Microphone is omnidirectional and it is connected to UEM microphone input MIC1P/N. The microphone input is asymmetric and the UEM (MICB1) provides the bias voltage. Nominal impedance of the microphone is 1.8kOhms. The microphone input to UEM is ESD protected. Spring contacts are used to connect the microphone to the main PWB. Microphone is mounted in LCD frame assembly.

IR module

The IR interface in case of transceiver with 1.8V I/O voltage is designed into UPP. The IR link supports transmission speeds from 9600 bit/s to 1.152 MBit/s up to distance of 80 cm. Transmission over the IR is half-duplex.

The length of the transmitted IR pulse depends on the speed of the transmission. When 230.4 kbit/s or less is used as a transmission speed, pulse length is maximum 1.63µs. If transmission speed is set to 1.152Mbit/s, the pulse length is 154ns.

Figure 28: IR module connections.

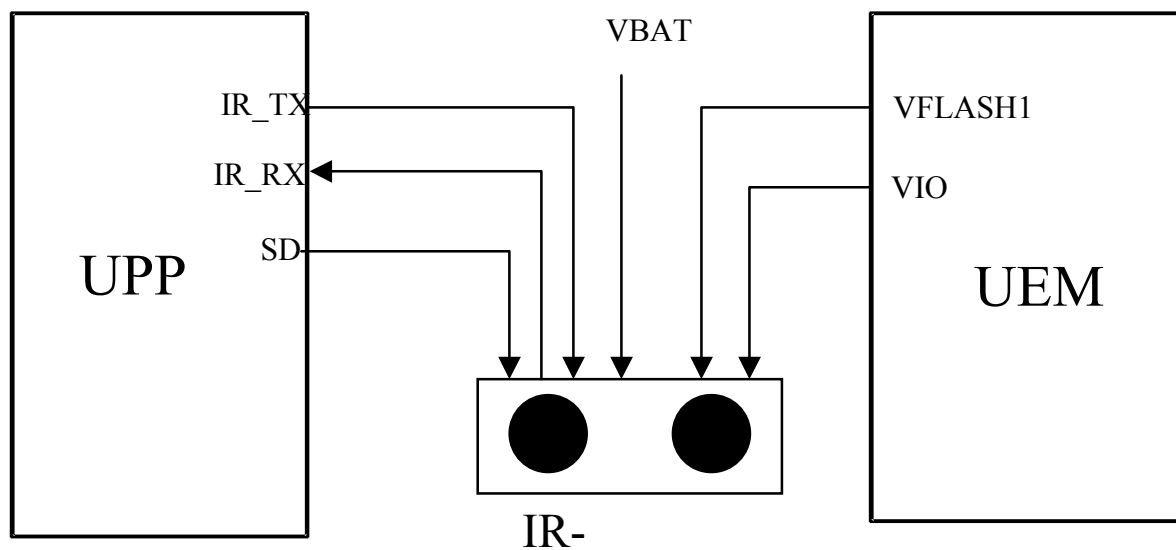

Vibra

A vibra alerting device is used to generate a vibration signal for an incoming call. Vibra is located in the bottom end of the phone and it is connected to main PWB with spring contacts. The vibra is controlled by a PWM signal from UEM. Frequency can be set to 64, 128, 256 or 512 Hz and duty cycle can vary between 3% - 97%. Vibra motor is mounted in C-cover assembly.

Pop-Port system connector

Pop-Port system connector consists of a charging plug socket and a Pop-Port System Connector. The Pop-Port is a feature based interface. The accessory contains information about its features (ACI ASIC) and it is detected with a fully digital detection procedure.

Table 3: Pop-Port functions.

Function	Note
Charging	Pads for 2 -wire charging in cradles
Audio	- 4 -wire fully differential stereo audio output - 2-wire differential microphone input - FM radio antenna connection
Power Supply for Accessories	2.78V/70 mA output to accessories
ACI (Accessory Control Interface)	Accessory detection/removal & controlling
FBUS	Standard FBUS
USB (Optional)	Note: Not used in RH-20

Figure 29: Pop-Port connections.

